



Integrato with  
zinc alloy foot



LEVELLERS





# SYMBOLS AND FINISHES LEGEND

## SYMBOLS

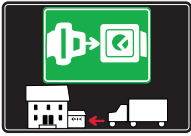

= SHELF SAFELY LOCKED DURING TRANSPORTATION AND AT HOME.



= ANTI-TURNOVER LOCKING SYSTEM



= NORMS / PATENTS



= PHILLIPS / POZIDRIV



= WITH BUFFER



= PART NO.



= BLADE SLOT



= WITH MAGNET



= PCS. PER PACKAGE



= COMBI SLOT



= HEXAGONAL SOCKET



= NEWTON



= CAPACITY LOADING



= HEXALOBULAR SOCKET



= FRICTION



= WOOD / GLASS THICKNESS



= COUNTERSUNK HEAD



= AUTOMATIC



= HOLE DIAMETER



= PAN HEAD



= DROP DOWN



= DIAMETER



= FLANGE HEAD



= LENGTH



= FLAT HEAD



= STANDARD HINGE



= HEIGHT



= TRILOBULAR SCREW



= KIMANA HINGE



= RIGHT VERSION



= SELF-TAPPING SCREW



= FLAP HINGE



= LEFT VERSION



= EURO THREAD



= WITH SPRING



= SETTING CODE



= METRIC THREAD



= WITHOUT SPRING



= PCS. PER PAD



= PRE-INSERTED SCREW



= REVERSED SPRING



= CUT ON REQUEST



= PRE-INSERTED SCREW AND SPREADING BUSH



= SELF ADHESIVE



= WITH FLANGE

NOTE: Printing errors and omissions may exist despite our best efforts to ensure accuracy. We reserve the right to alter specifications without notice.

## MATERIALS

<b>ZA</b> = Zinc Alloy	<b>ST</b> = Steel	<b>HSS</b> = High Speed Steel	<b>BR</b> = Brass	<b>ABS</b> = Acrylonitrile Butadiene Styrene
<b>ZAnk</b> = Nickel-plated Zinc Alloy	<b>STzk</b> = Zinc-plated Steel	<b>AL</b> = Aluminium	<b>WD</b> = Wood	<b>EVA</b> = Ethylene Vinyl Acetate
<b>EP</b> = <b>ENGINEERING PLASTIC</b>			<b>SR</b> = <b>SOFT RUBBER</b>	
+ <b>EP</b> = other engineering plastic available on request			+ <b>SR</b> = other soft rubber available on request	
<b>EPn</b> = Natural Engineering Plastic	<b>EPc</b> = Clear Engineering Plastic	<b>SRn</b> = Natural Soft Rubber		
<b>EPw</b> = White Engineering Plastic	<b>EPg</b> = Grey Engineering Plastic	<b>SRw</b> = White Soft Rubber		
<b>EPwg</b> = Water Green Engineering Plastic	<b>EPa</b> = Anthracite Engineering Plastic	<b>SRb</b> = Black Soft Rubber		



## FINISHES



+ **OTHER FINISHES AVAILABLE ON REQUEST**

PART NO.	FINISHES	PART NO.	FINISHES	PART NO.	FINISHES
00	Insignificant finish	IF	Middle Grey	RO	Red
AA	Natural	IJ	Light Grey	UT	T-Met 9007
AB	White	IL	Grey 20	UZ	T-Met
AE	White 9010	IN	Grey met. 26	WA	Bronzed
EA	Black	JB	Bright Aluminium	WI	Burnished
EC	Matt Black	JC	Aluminium - Chrome	XD	Satin-finished Steel
EE	Anthracite	JD	Matt Aluminium	YA	Nickel-plated
EW	Grey 9007	JE	Satin-finished Aluminium	YB	Bright Nickel-plated
FU	Gunmetal	JF	Aluminium - Brass	YC	Matt Nickel-plated
FV	Gunmetal V52	JG	Aluminium 5	YD	Satin-finished Nickel-plated
GR	Raw	JL	Aluminium PE 11	YQ	Black Nickel
HA	Brass-Plated	JM	Aluminium RAL 9006	Z9	Black Zinc
HH	Tropicalized	KA	Chrome	ZA	Zinc alloy
HL	Raw Brass	KB	Bright Chrome	ZN	Zinc-plated
HX	Graphite	KC	Matt Chrome	ZQ	Bright Gold
IA	Grey	LD	Brown 8019	ZY	Titanium
IB	Metallic Grey	NN	Metallic Beige	ZZ	Clear



## INTEGRATO WITH ZINC ALLOY FOOT



INTEGRATO is a complete family of levellers suitable to align heavy duty wardrobes, bookcases and modular furniture.

The leveller is installed and safely fixed onto the bottom of the carcass through a wide range of supports such as pins and screw holes, spikes and screw holes or just screw holes.

A further securement in position can be obtained with a countersunk 4x18 mm length screw from underneath first and then with two panhead 3,5x15 mm length screws from the side if required.

The adjustment of the leveller can be carried out from above through a Ø 8 mm hole on the bottom panel, by using a S6mm allen wrench or both cross and blade screwdriver.

The zinc alloy die-cast foot is provided with an independent engineering plastic glide in order to make the adjustment easier and to prevent the scratching of the floor.

A bespoke spacer can be slotted over the leveller to give an extra structural support to the furniture bottom. The spacer is available in three heights.

INTEGRATO levellers are available with 12 mm adjustment

and 25 mm adjustment, with main body in zinc alloy or with engineering plastic.

175 Kg per piece

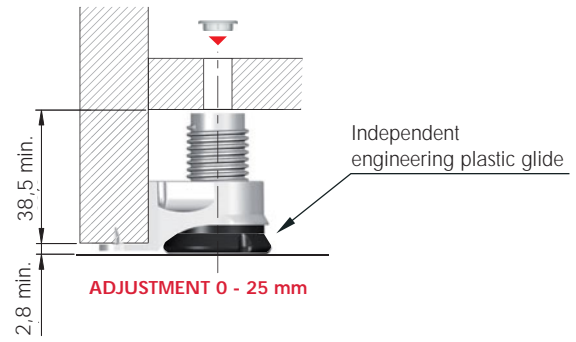
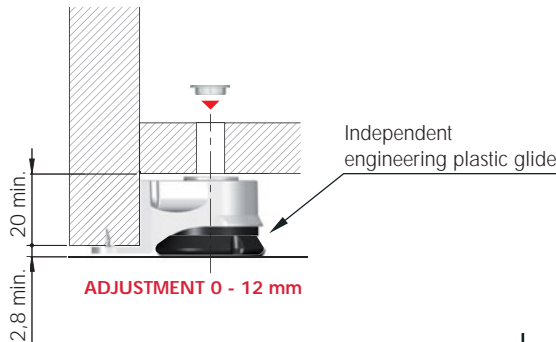

### INSTALLATION

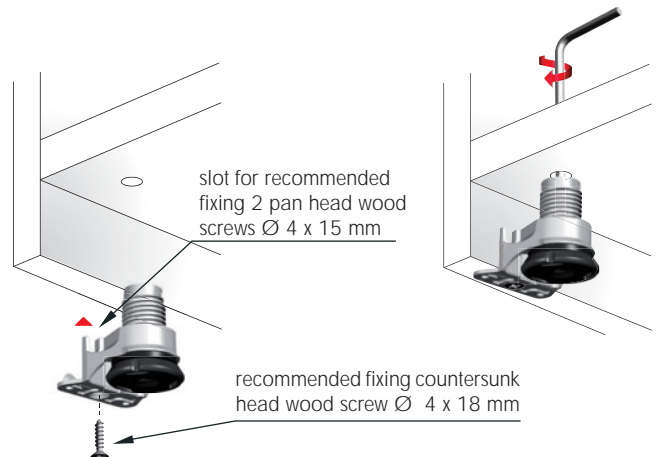
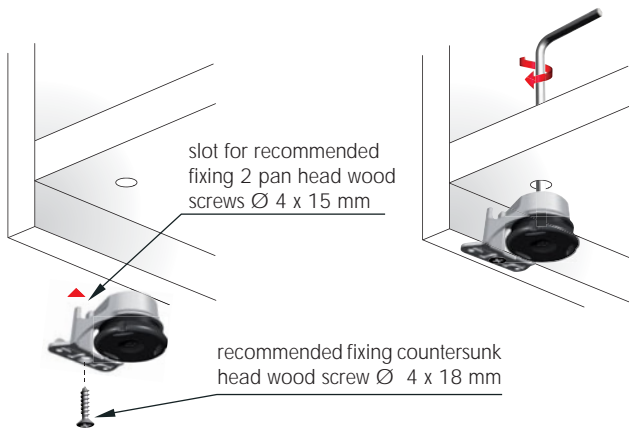

### ADJUSTMENT

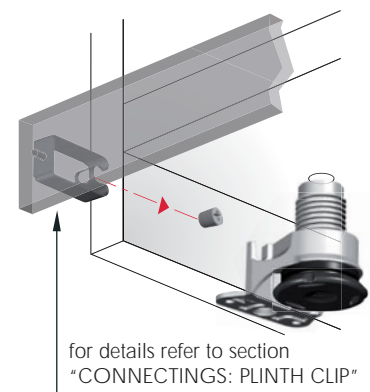
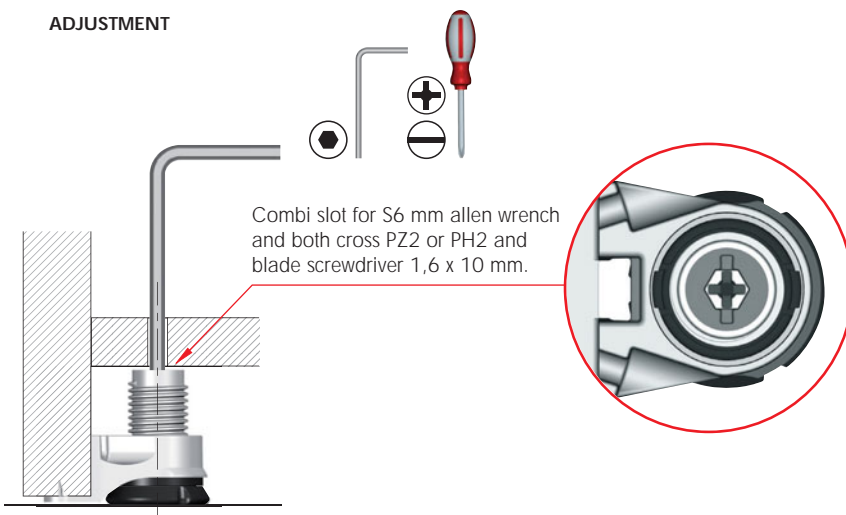



## INTEGRATO A

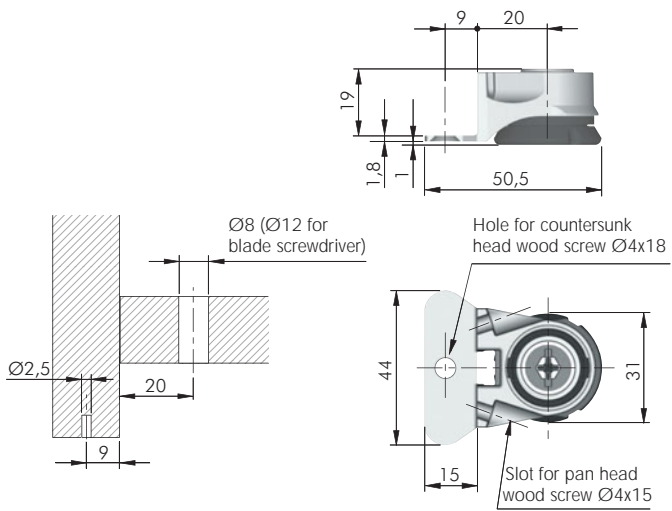

### ADJUSTMENT 0 - 12 mm



= 300 pcs.



**3010101000**



S6 mm



PZ2 - PH2



1,6x10 mm

**3010104000**

S4/S6 mm

-

-

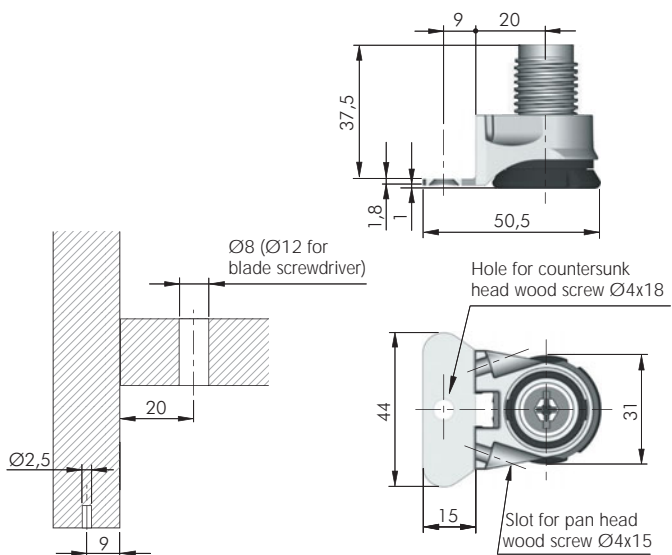
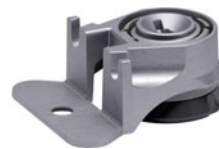

### ADJUSTMENT 0 - 25 mm



= 250 pcs.



**3010102000**



S6 mm



PZ2 - PH2



1,6x10 mm

**3010105000**

S4/S6 mm

-

-



## INTEGRATO B

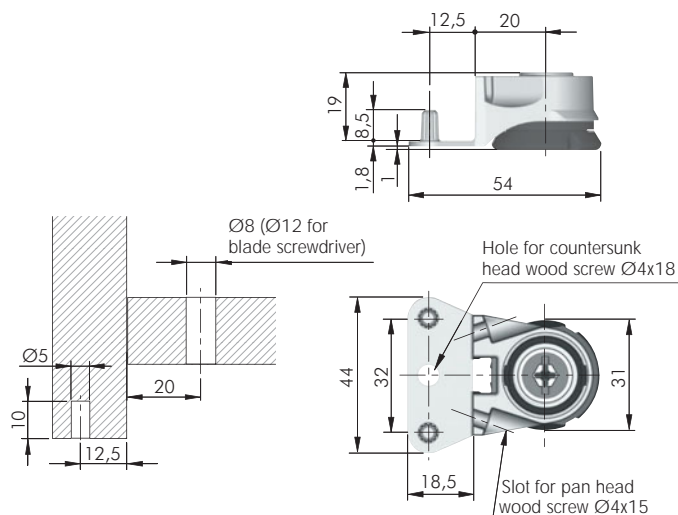

### ADJUSTMENT 0 - 12 mm



= 250 pcs.



**3010201000**





LEVELLERS

# INTEGRATO WITH ZINC ALLOY FOOT

**ITALIANA**  
ferramenta

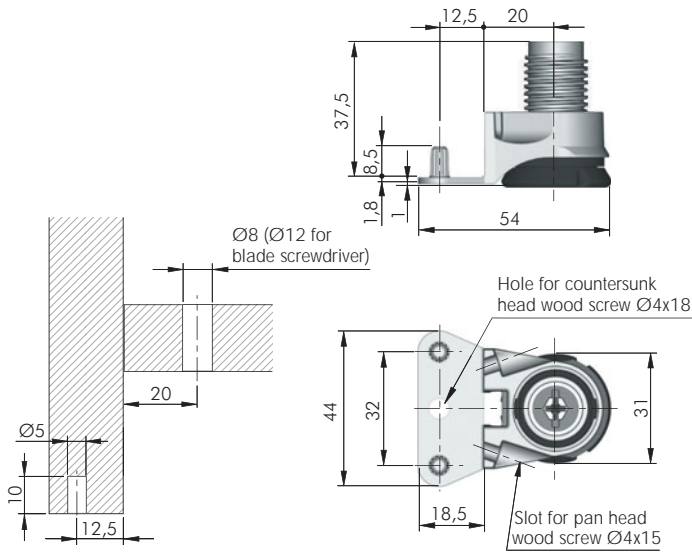

**ADJUSTMENT 0 - 25 mm**

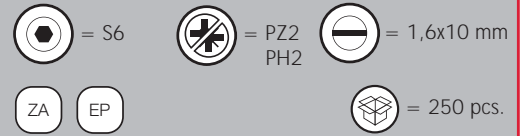

3010202000



## INTEGRATO C

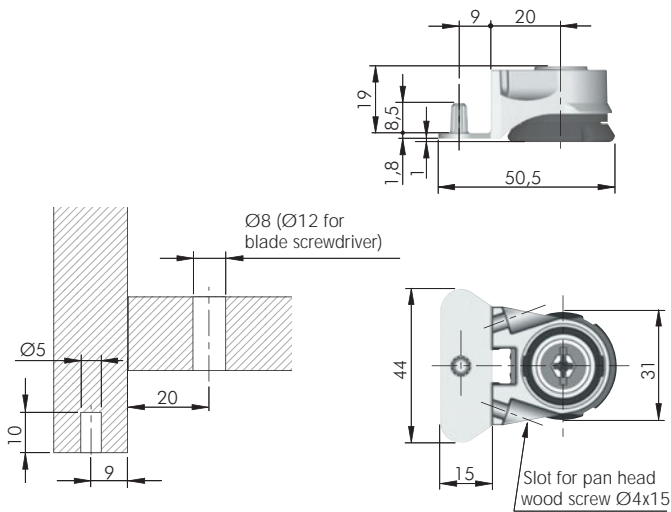

**ADJUSTMENT 0 - 12 mm**

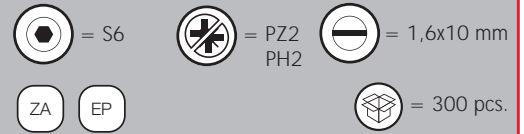

3010301000

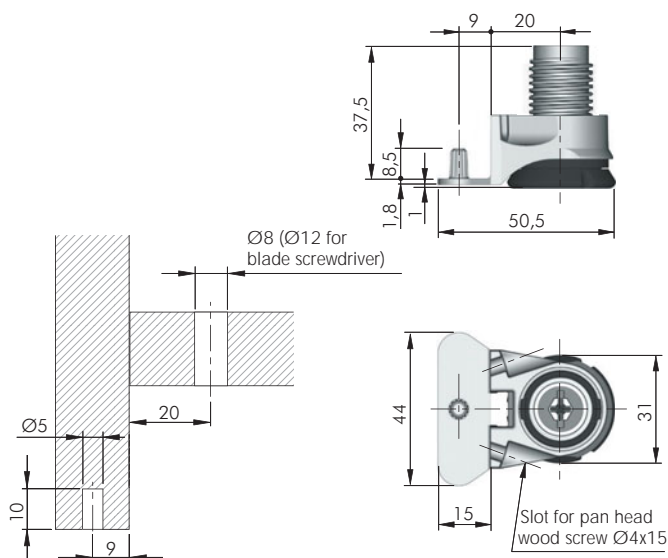

**ADJUSTMENT 0 - 25 mm**

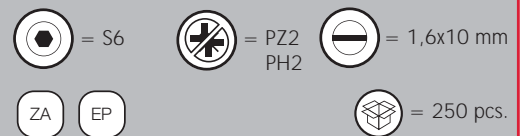

3010302000





## INTEGRATO D

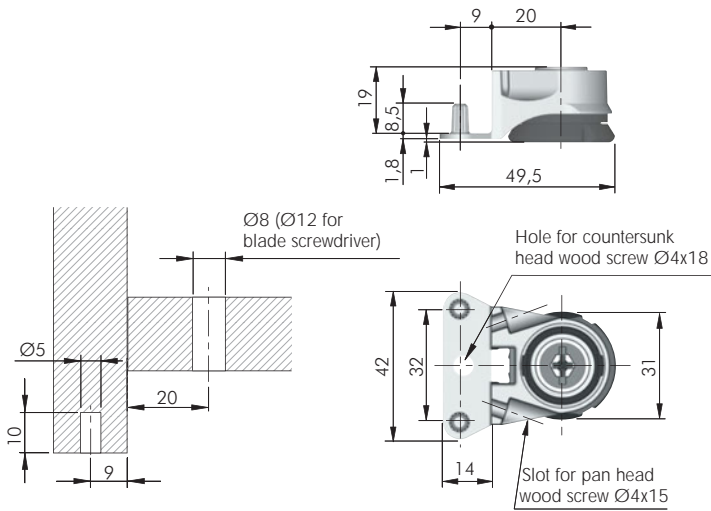

### ADJUSTMENT 0 - 12 mm

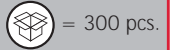

3010401000



S6 mm



PZ2 - PH2



1,6x10 mm

3010405000

S4/S6 mm

-

-

## INTEGRATO E

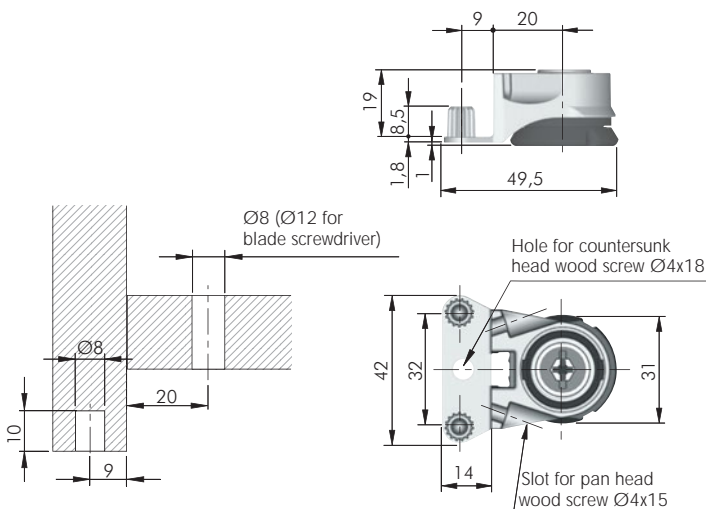

### ADJUSTMENT 0 - 12 mm



PZ2  
PH2

1,6x10 mm

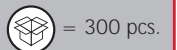

3010501000





LEVELLERS

# INTEGRATO WITH ZINC ALLOY FOOT

**ITALIANA**  
ferramenta

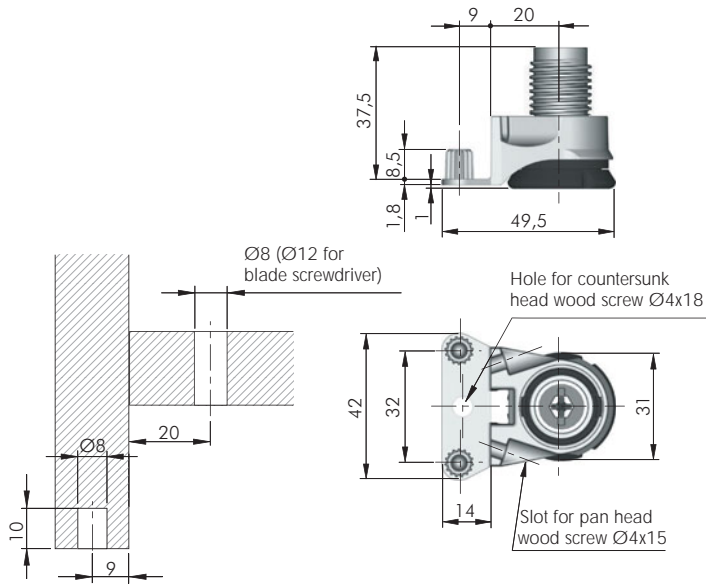

### ADJUSTMENT 0 - 25 mm

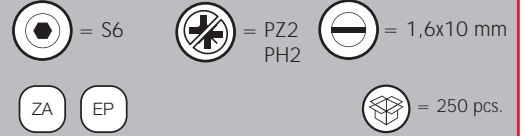

3010502000



## INTEGRATO G

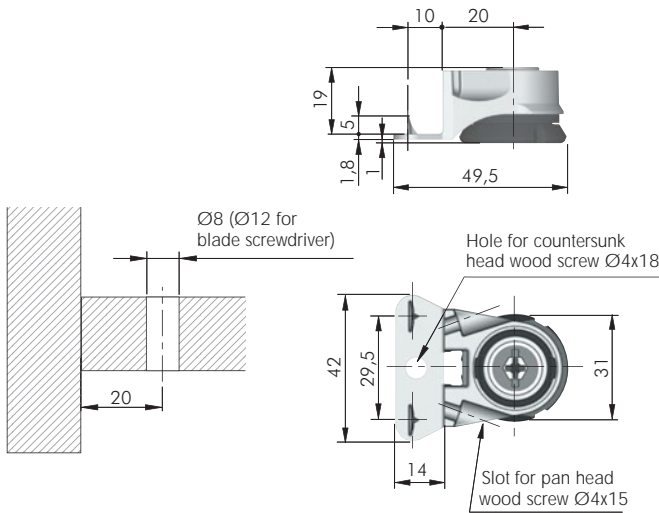

### ADJUSTMENT 0 - 12 mm

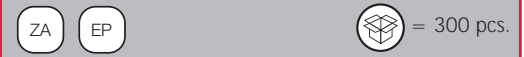

3010601000



S6 mm



PZ2 - PH2



1,6x10 mm

3010603000

S4/S6 mm

-

-

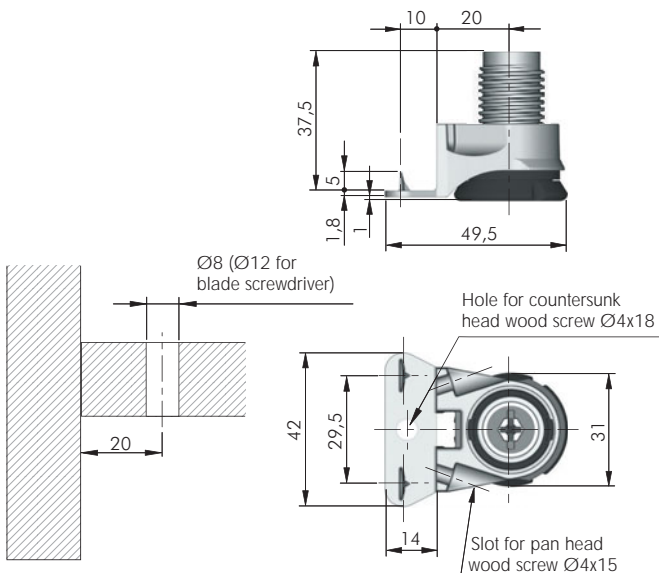

### ADJUSTMENT 0 - 25 mm

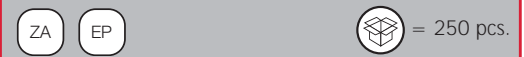

3010602000



S6



PZ2 - PH2



1,6x10 mm

3010604000

S4/S6 mm

-

-







## INTEGRATO ACCESSORY

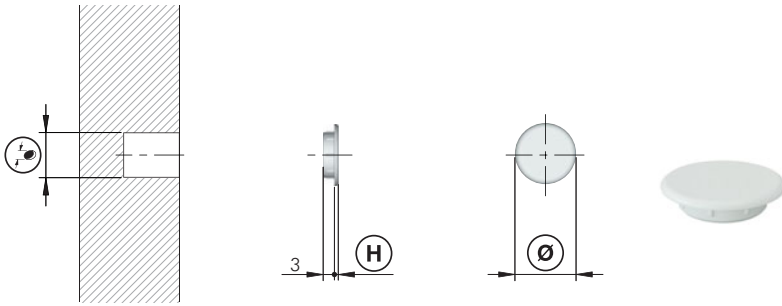

= Ø 8, Ø 12 mm					+
EP					
<b>23002010AB</b>	Ø 8	Ø 11	1	5000	
<b>23002030AB</b>	Ø 12	Ø 15	1	5000	

## INTEGRATO FIXING ACCESSORIES



= Ø 3 mm					+
			= PZ2		
ST					= 1000 pcs.
<b>60101580ZN</b>					

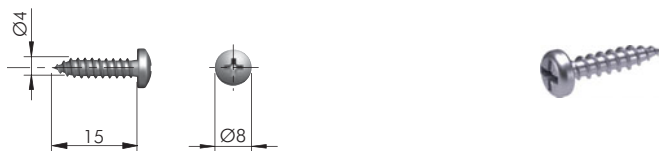

= Ø 3 mm					+
			= PZ2		
ST					= 1000 pcs.
<b>60103230ZN</b>					



Integrato with  
engineering plastic  
foot

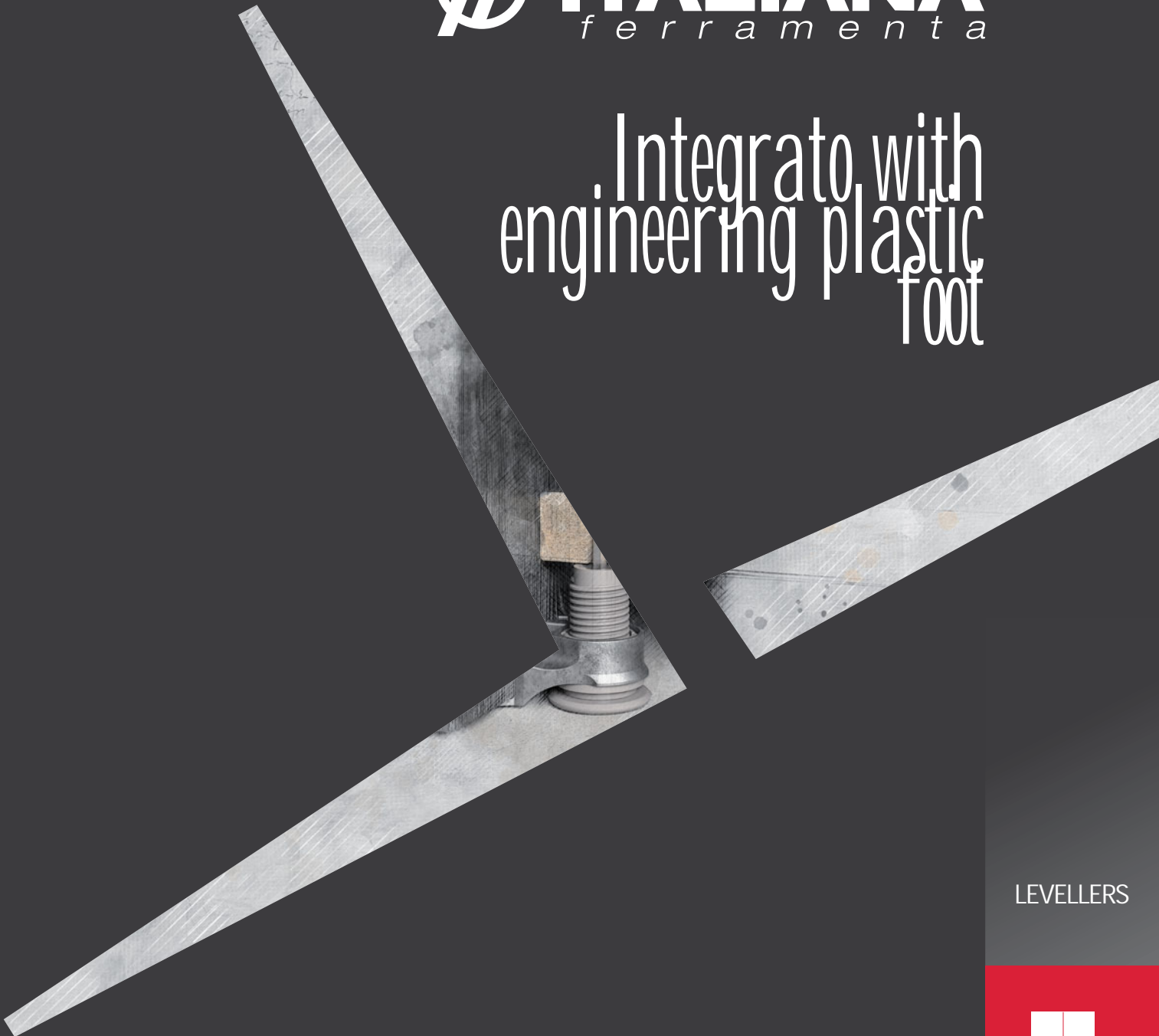

LEVELLERS





LEVELLERS

# INTEGRATO WITH ENGINEERING PLASTIC FOOT

**ITALIANA**  
ferramenta

## INTEGRATO WITH ENGINEERING PLASTIC FOOT



INTEGRATO is a complete family of levellers suitable to align heavy duty wardrobes, bookcases and modular furniture.

The leveller is installed and safely fixed onto the bottom of the carcass through a wide range of supports such as pins and screw holes, spikes and screw holes or just screw holes.

A further securement in position can be obtained with a countersunk 4x18 mm length screw from underneath first and then with two panhead 3,5x15mm length screws from the side if required.

The adjustment of the leveller can be carried out from above through a Ø 8 mm hole on the bottom panel, by using a S6mm allen wrench or both cross and blade screwdriver.

A bespoke spacer can be slotted over the leveller to give an extra structural support to the furniture bottom. The spacer is available in three heights.

INTEGRATO levellers are available with 12 mm adjustment and 25 mm adjustment, with main body in zinc alloy or with engineering plastic.

175 Kg per piece

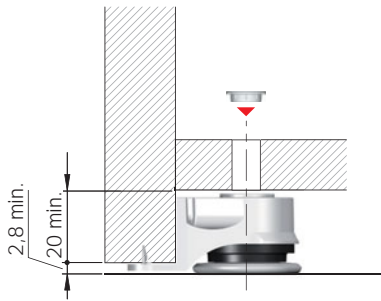

ADJUSTMENT 0 - 12 mm

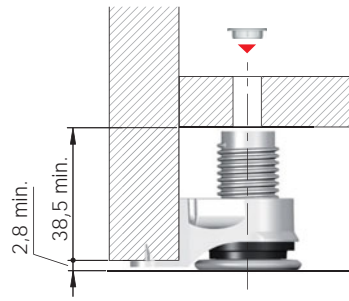

ADJUSTMENT 0 - 25 mm

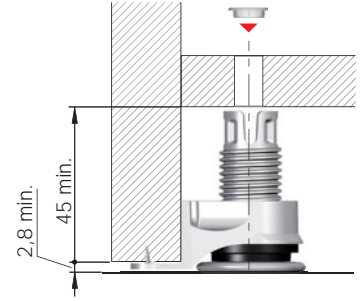

### INSTALLATION

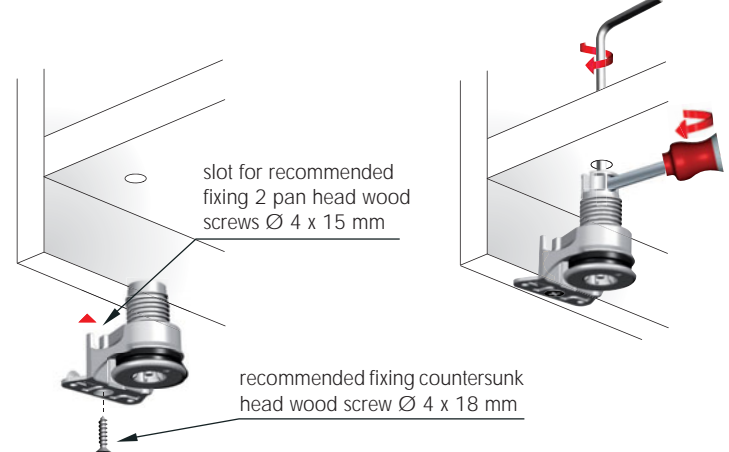
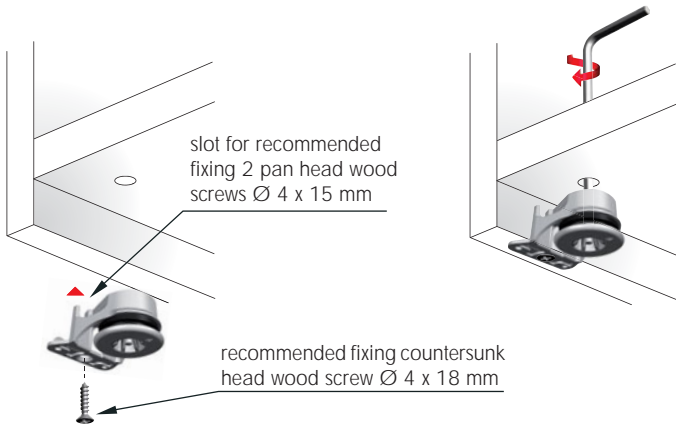

### ADJUSTMENT

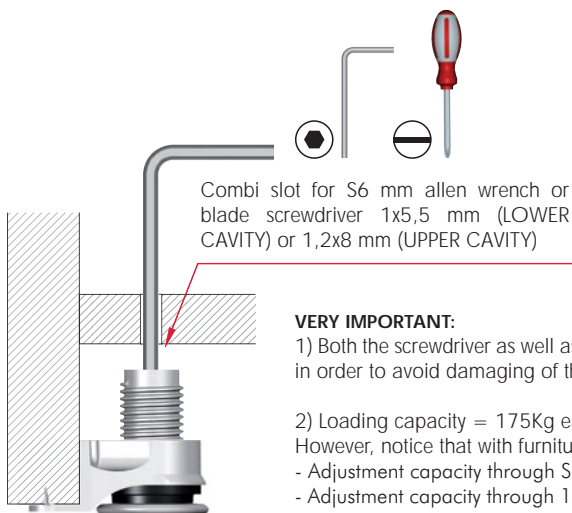

Combi slot for S6 mm allen wrench or blade screwdriver 1x5,5 mm (LOWER CAVITY) or 1,2x8 mm (UPPER CAVITY)

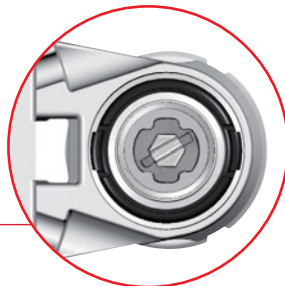

#### VERY IMPORTANT:

1) Both the screwdriver as well as the allen wrench must be fully inserted in the cavities, in order to avoid damaging of the engineering plastic sockets.

2) Loading capacity = 175Kg each.

However, notice that with furniture already loaded:

- Adjustment capacity through S6 mm allen wrench  $\leq$  175Kg.
- Adjustment capacity through 1x5,5 mm blade screwdriver (LOWER CAVITY)  $\leq$  63Kg.
- Adjustment capacity through 1,2x8 mm blade screwdriver (UPPER CAVITY)  $\leq$  63Kg.

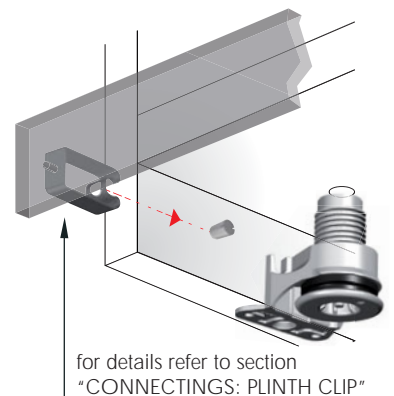

for details refer to section "CONNECTINGS: PLINTH CLIP"

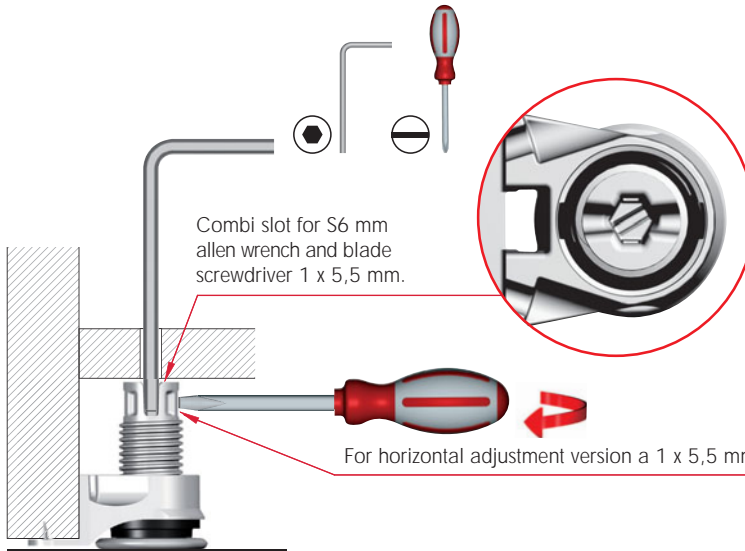

**VERY IMPORTANT:**

1) Both the screwdriver as well as the allen wrench must be fully inserted in the cavities, in order to avoid damaging of the engineering plastic sockets.

2) Loading capacity = 175 Kg each.

However, notice that with furniture already loaded:

- Horizontal adjustment capacity through 1x5,5 mm blade screwdriver ≤ 175 Kg.
- Vertical adjustment capacity through S6 mm allen wrench ≤ 175 Kg.
- Vertical adjustment capacity through 1x5,5 mm blade screwdriver ≤ 63 Kg.

For horizontal adjustment version a 1 x 5,5 mm blade screwdriver is required.

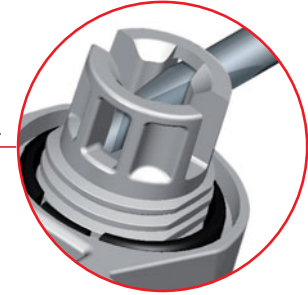

### INTEGRATO A

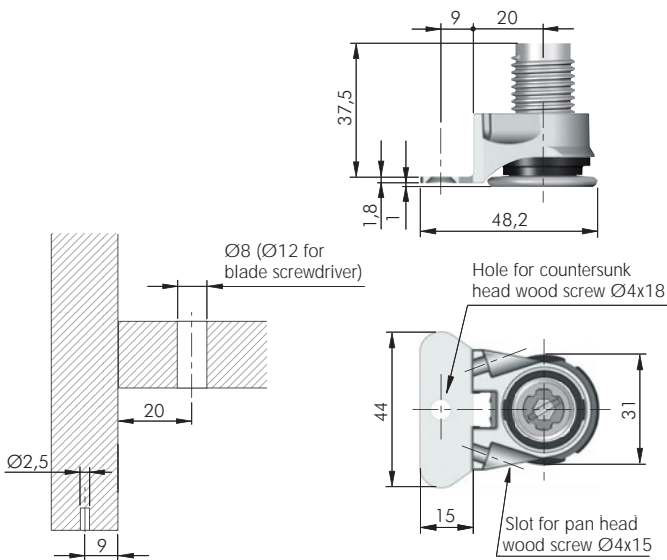

**ADJUSTMENT 0 - 25 mm**

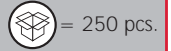

3011103000



### INTEGRATO B

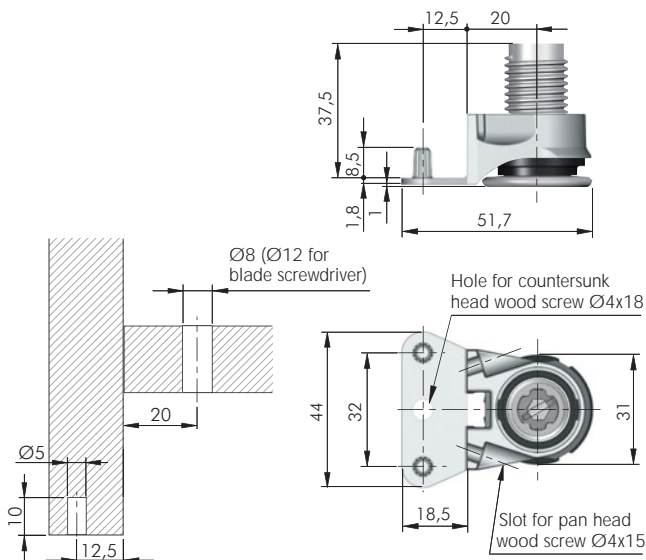

**ADJUSTMENT 0 - 25 mm**

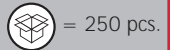
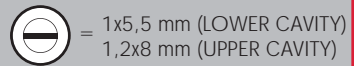

3011203000





LEVELLERS

# INTEGRATO WITH ENGINEERING PLASTIC FOOT

**ITALIANA**  
ferramenta

## INTEGRATO C

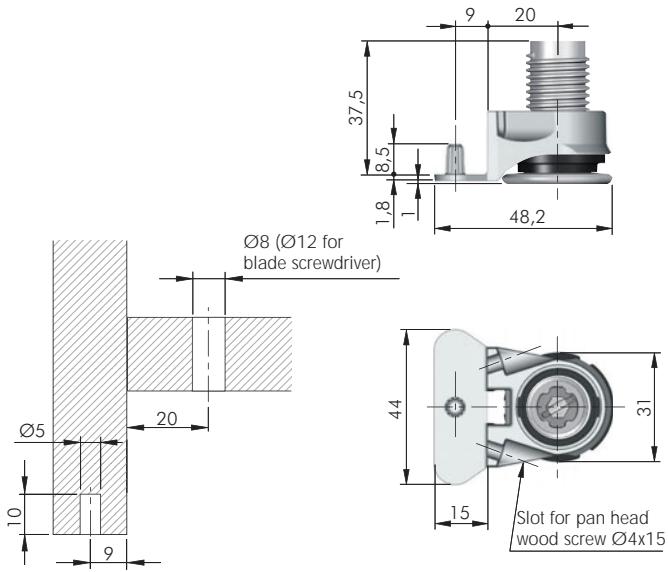

ADJUSTMENT 0 - 25 mm

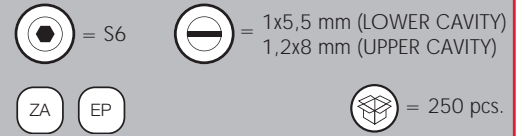

3011303000

## INTEGRATO D

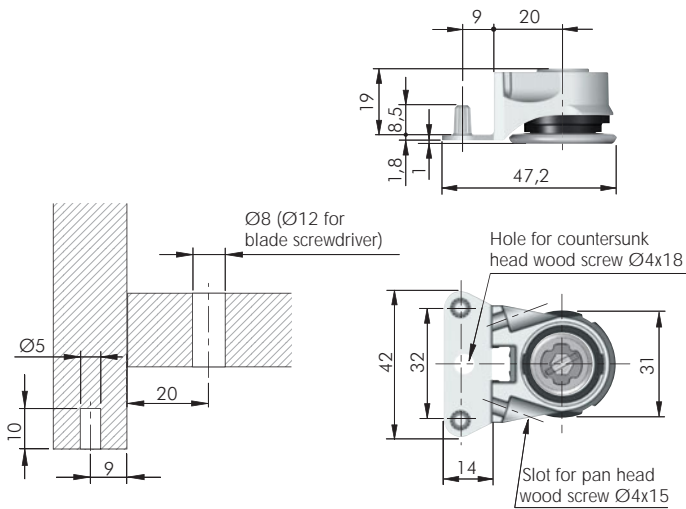

ADJUSTMENT 0 - 12 mm

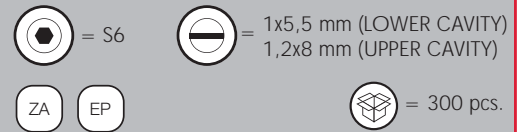

3011401000

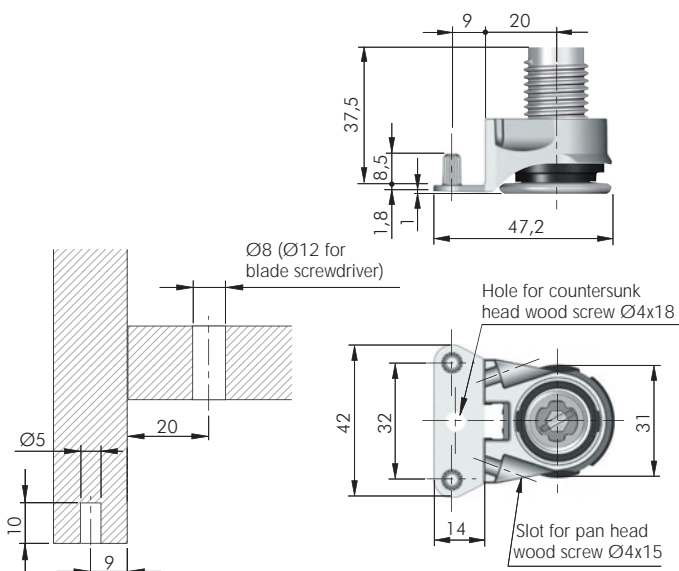

ADJUSTMENT 0 - 25 mm

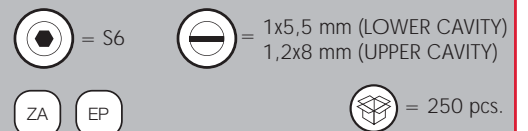

3011403000

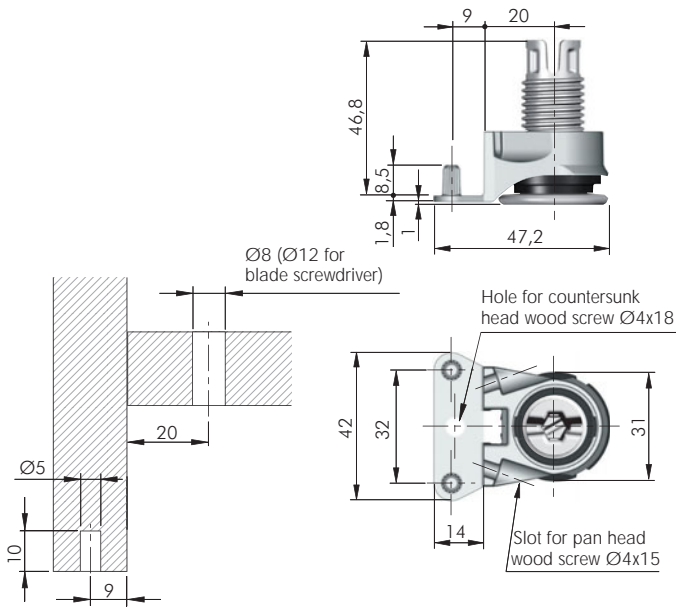

**ADJUSTMENT 0 - 25 mm**

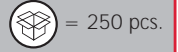

3011402000

## INTEGRATO E

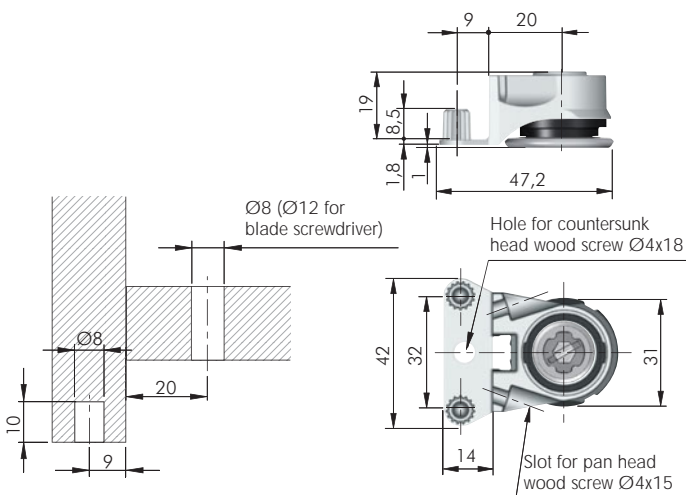

**ADJUSTMENT 0 - 12 mm**

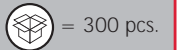
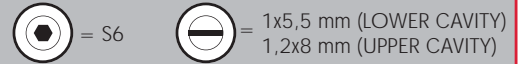

3011501000

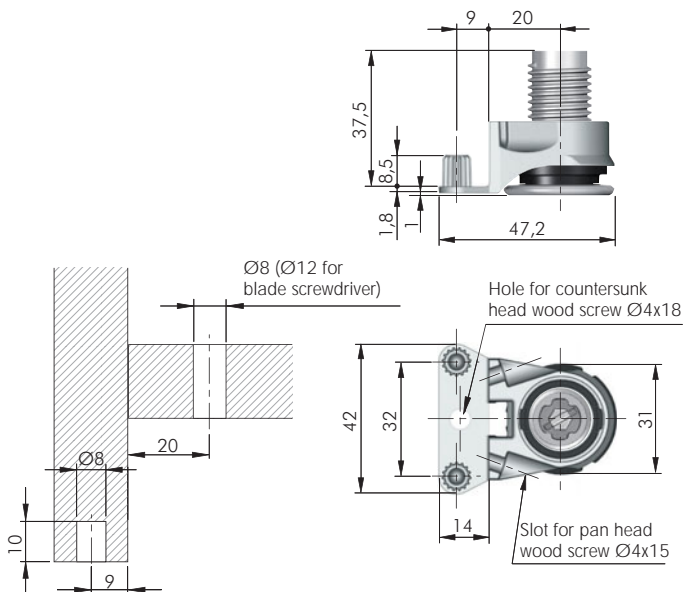

**ADJUSTMENT 0 - 25 mm**

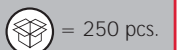
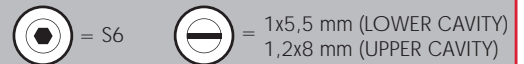

3011503000



LEVELLERS

# INTEGRATO WITH ENGINEERING PLASTIC FOOT

**ITALIANA**  
ferramenta

## INTEGRATO G

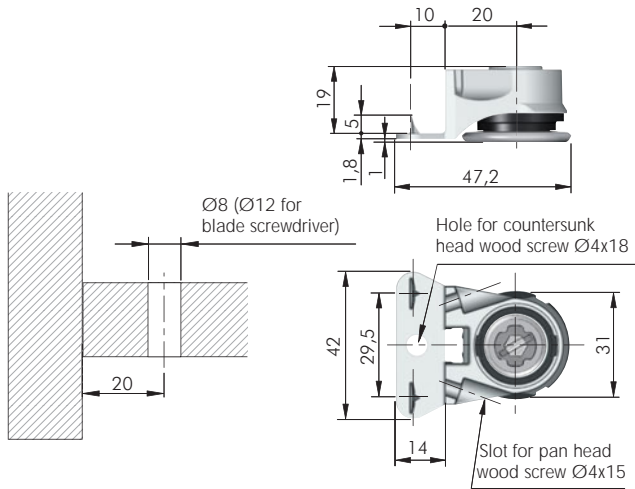

### ADJUSTMENT 0 - 12 mm



1x5,5 mm (LOWER CAVITY)  
1,2x8 mm (UPPER CAVITY)



300 pcs.



3011601000

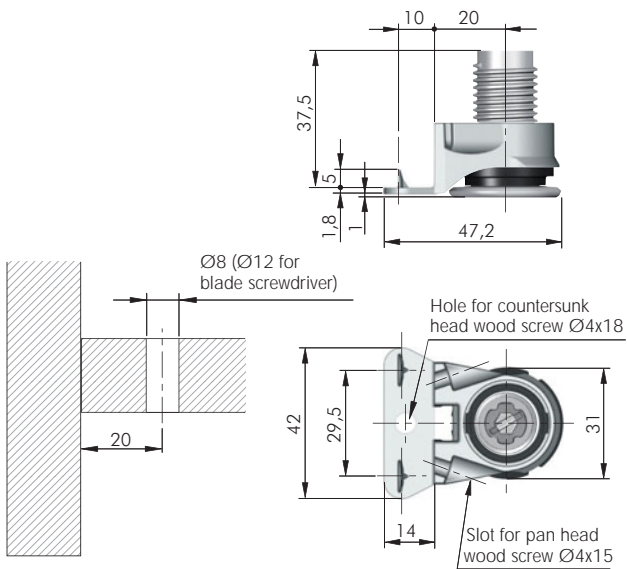

### ADJUSTMENT 0 - 25 mm



1x5,5 mm (LOWER CAVITY)  
1,2x8 mm (UPPER CAVITY)



250 pcs.



3011603000

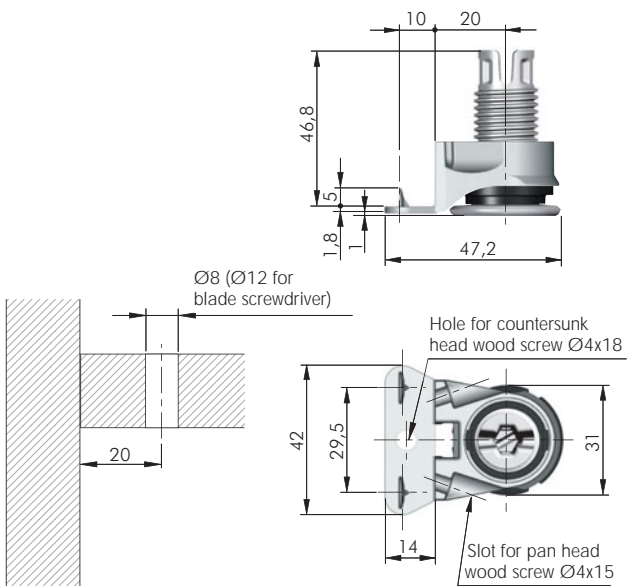

### ADJUSTMENT 0 - 25 mm



1x5,5 mm



250 pcs.



3011602000





## INTEGRATO ACCESSORY

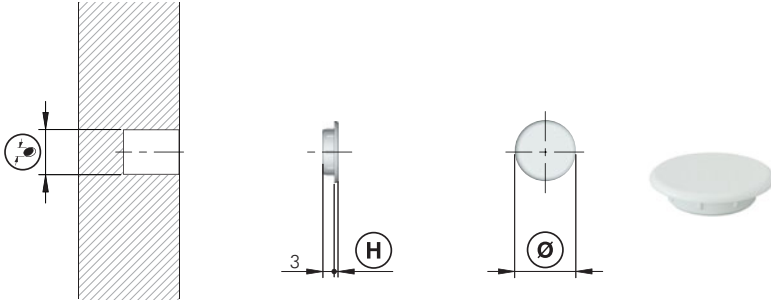

= Ø 8, Ø 12 mm					+
EP					
123					
<b>23002010AB</b>	Ø 8	Ø 11	1	5000	
<b>23002030AB</b>	Ø 12	Ø 15	1	5000	

## INTEGRATO FIXING ACCESSORIES

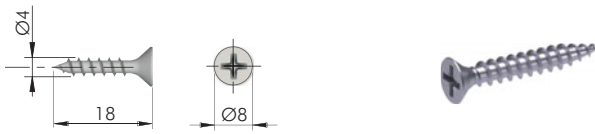

= Ø 3 mm					+
= PZ2					
ST					= 1000 pcs.
123					
<b>60101580ZN</b>					

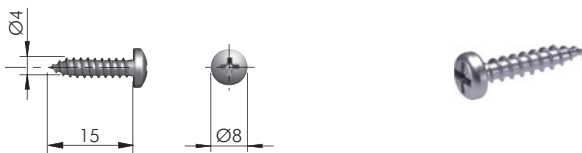

= Ø 3 mm					+
= PZ2					
ST					= 1000 pcs.
123					
<b>60103230ZN</b>					

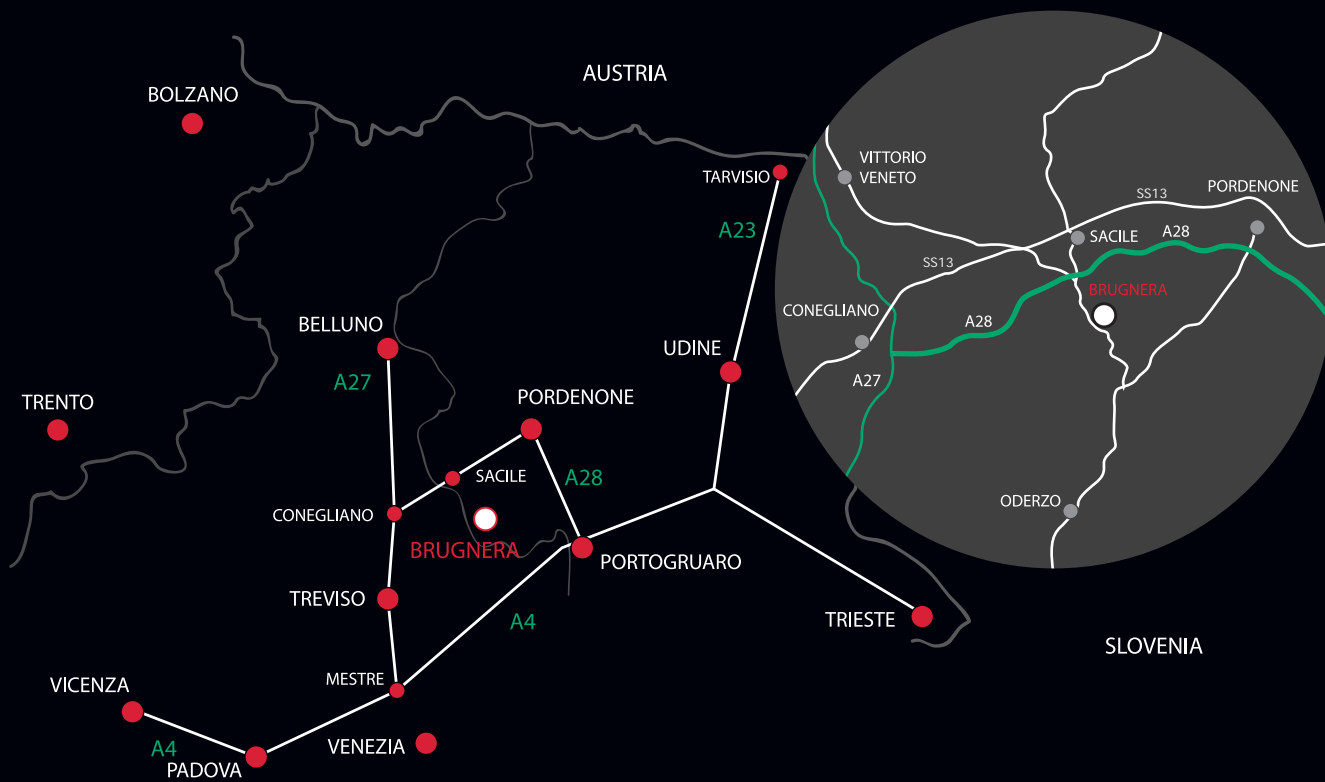

[www.italianaferramenta.it](http://www.italianaferramenta.it)