



Standard soft close hinge

105° opening angle for Door thickness of 14-22mm

Metal material, Cu-Nickel / Cu-black nickel plated

Integrated silent system

According to EN15570 standard, durable and stable

Easy clip on and tool-free door to cabinet assembly and removal

3-Dimensional adjustment

Hinge Installation

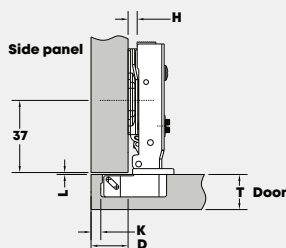
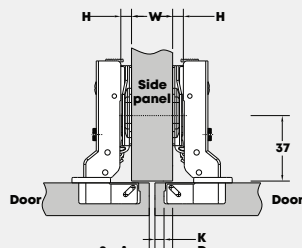
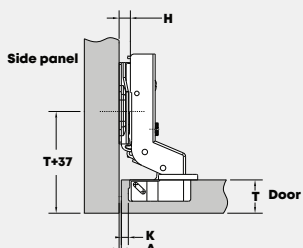
Full Overlay	Half Overlay	Inset																																																																																				
 <p>$H=14+K-D$</p> <table border="1"> <thead> <tr> <th>D</th> <th>K</th> <th>3</th> <th>4</th> <th>5</th> <th>6</th> <th>7</th> </tr> </thead> <tbody> <tr> <td>0</td> <td>H</td> <td>17</td> <td>18</td> <td>19</td> <td>20</td> <td>21</td> </tr> <tr> <td>2</td> <td>H</td> <td>15</td> <td>16</td> <td>17</td> <td>18</td> <td>19</td> </tr> <tr> <td>4</td> <td>H</td> <td>13</td> <td>14</td> <td>15</td> <td>16</td> <td>17</td> </tr> </tbody> </table>	D	K	3	4	5	6	7	0	H	17	18	19	20	21	2	H	15	16	17	18	19	4	H	13	14	15	16	17	 <p>$H=4+K-D$</p> <table border="1"> <thead> <tr> <th>D</th> <th>K</th> <th>3</th> <th>4</th> <th>5</th> <th>6</th> <th>7</th> </tr> </thead> <tbody> <tr> <td>0</td> <td>H</td> <td>7</td> <td>8</td> <td>9</td> <td>10</td> <td>11</td> </tr> <tr> <td>2</td> <td>H</td> <td>5</td> <td>6</td> <td>7</td> <td>8</td> <td>9</td> </tr> <tr> <td>4</td> <td>H</td> <td>3</td> <td>4</td> <td>5</td> <td>6</td> <td>7</td> </tr> </tbody> </table>	D	K	3	4	5	6	7	0	H	7	8	9	10	11	2	H	5	6	7	8	9	4	H	3	4	5	6	7	 <p>$H=-4+K+A$</p> <table border="1"> <thead> <tr> <th>A</th> <th>K</th> <th>3</th> <th>4</th> <th>5</th> <th>6</th> <th>7</th> </tr> </thead> <tbody> <tr> <td>0</td> <td>H</td> <td>1</td> <td>0</td> <td>-1</td> <td>-2</td> <td>-3</td> </tr> <tr> <td>2</td> <td>H</td> <td>3</td> <td>2</td> <td>1</td> <td>0</td> <td>-1</td> </tr> <tr> <td>4</td> <td>H</td> <td>5</td> <td>4</td> <td>3</td> <td>2</td> <td>1</td> </tr> </tbody> </table>	A	K	3	4	5	6	7	0	H	1	0	-1	-2	-3	2	H	3	2	1	0	-1	4	H	5	4	3	2	1
D	K	3	4	5	6	7																																																																																
0	H	17	18	19	20	21																																																																																
2	H	15	16	17	18	19																																																																																
4	H	13	14	15	16	17																																																																																
D	K	3	4	5	6	7																																																																																
0	H	7	8	9	10	11																																																																																
2	H	5	6	7	8	9																																																																																
4	H	3	4	5	6	7																																																																																
A	K	3	4	5	6	7																																																																																
0	H	1	0	-1	-2	-3																																																																																
2	H	3	2	1	0	-1																																																																																
4	H	5	4	3	2	1																																																																																

MINIMUM REVEAL TABLE

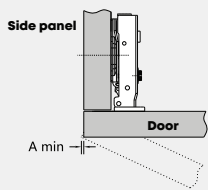

A	K	T	14	15	16	17	18	19	20	21	22
3	K	T	0.3	0.5	0.7	0.9	1.2	1.5	1.8	2.2	2.6
4	K	T	0.3	0.5	0.7	0.9	1.1	1.4	1.8	2.1	2.5
5	K	T	0.2	0.4	0.6	0.9	1.1	1.4	1.7	2.0	2.4
6	K	T	0.2	0.4	0.6	0.8	1.1	1.3	1.6	2.0	2.4
7	K	T	0.2	0.4	0.5	0.8	1.0	1.3	1.6	1.9	2.3

K = Drilling distance

T = Door thickness

A = Minimum gap (A) for door with a door edge radius

L = Gap between door and panel

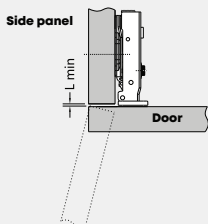

L	K	T	14	15	16	17	18	19	20	21	22
3	K	T	1.0	1.0	1.0	1.0	1.0	1.0	1.0	1.0	1.0
4	K	T	1.0	1.0	1.0	1.0	1.0	1.0	1.0	1.0	1.2
5	K	T	1.0	1.0	1.0	1.0	1.0	1.3	1.5	1.8	2.0
6	K	T	1.0	1.3	1.5	1.8	2.0	2.3	2.5	2.8	3.0
7	K	T	2.0	2.3	2.5	2.7	3.0	3.2	3.5	3.7	3.9

Note: above parameter based on the door edge is right-angle side, if the door is round corner edge, the parameter value will be reduce according to the edge size.

Hinge Quantity for Door

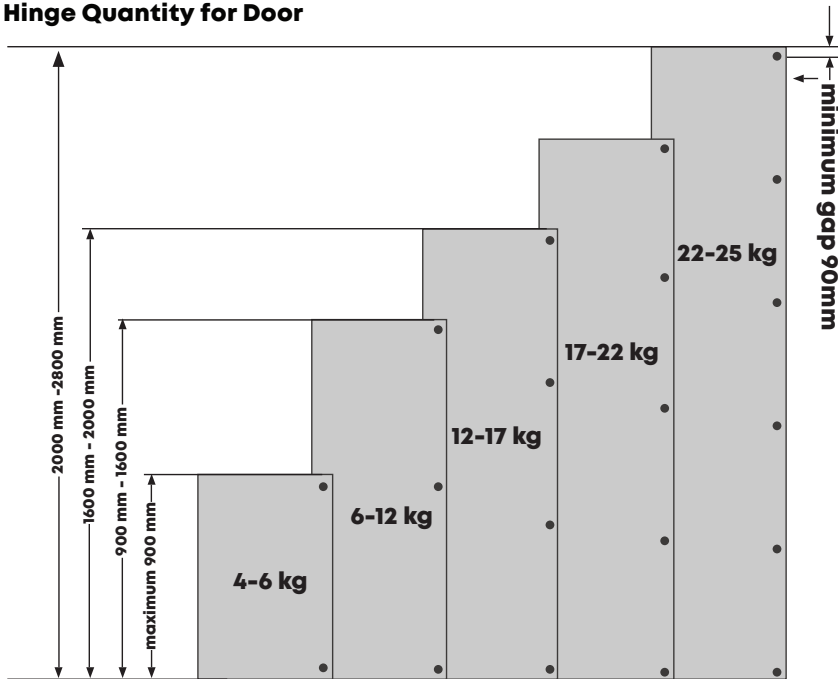

DRILLING FOR CUP

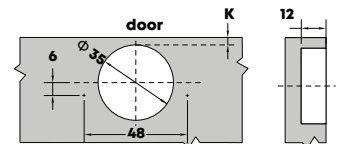

CUP INSTALLATION

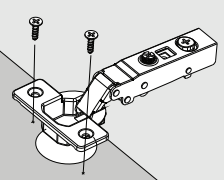
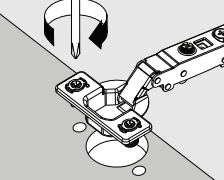
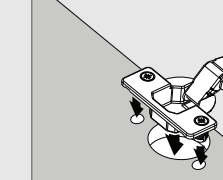
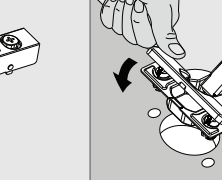
			
Screw on	Expanding	Knock-in	Toolless fast fixed cup
Wood screws	Ø 8mm expansive dowel	Ø 8mm dowel	8mm expanding dowels cover toolless fast fixed cup
Euro screws	Ø 10mm expansive dowel	Ø 10mm dowel	

HINGE ADJUSTMENT

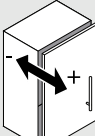
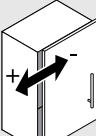
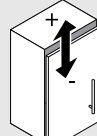
Depth Adjustment 	Overlay Adjustment 	Height Adjustment 
Rotate depth screw to adjust door gap. Adjust range : 3.8mm (cam screw) 5mm (depth screw)	Rotate lateral screw to increase or decrease door overlay. Adjust range : 6mm	Adjust the mounting plate on panel to adjust the door's height.

Notice: The reference adjustment range is the product design range, the actual size of the cabinet and the drilling method may have a certain impact on the parameters.



- Wide open 165° Soft close hinge
- 165° opening angle for Door thickness of 14-26mm
- Metal/zinc alloy material, Cu-Nickel/Cu-black nickel plated
- Integrated silent system
- According to EN15570 standard, Durable and stable
- Small angle soft close
- 3-dimensional adjustment

Hinge Installation

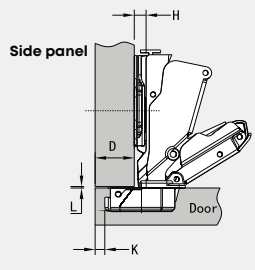
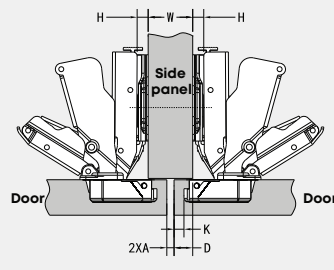
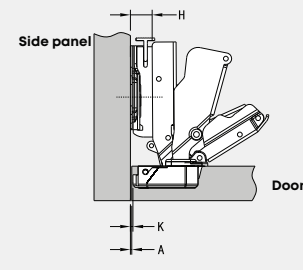
Full Overlay	Half Overlay	Inset																																																																													
 <p>H=14+K-D</p> <table border="1"> <thead> <tr> <th>D</th> <th>K</th> <th>3</th> <th>4</th> <th>5</th> <th>6</th> <th>7</th> </tr> </thead> <tbody> <tr> <td>0</td> <td>H</td> <td>17</td> <td>18</td> <td>19</td> <td>20</td> <td>21</td> </tr> <tr> <td>2</td> <td>H</td> <td>15</td> <td>16</td> <td>17</td> <td>18</td> <td>19</td> </tr> <tr> <td>4</td> <td>H</td> <td>13</td> <td>14</td> <td>15</td> <td>16</td> <td>17</td> </tr> </tbody> </table>	D	K	3	4	5	6	7	0	H	17	18	19	20	21	2	H	15	16	17	18	19	4	H	13	14	15	16	17	 <p>H=4+K-D</p> <table border="1"> <thead> <tr> <th>D</th> <th>K</th> <th>3</th> <th>4</th> <th>5</th> <th>6</th> <th>7</th> </tr> </thead> <tbody> <tr> <td>0</td> <td>H</td> <td>7</td> <td>8</td> <td>9</td> <td>10</td> <td>11</td> </tr> <tr> <td>2</td> <td>H</td> <td>5</td> <td>6</td> <td>7</td> <td>8</td> <td>9</td> </tr> <tr> <td>4</td> <td>H</td> <td>3</td> <td>4</td> <td>5</td> <td>6</td> <td>7</td> </tr> </tbody> </table>	D	K	3	4	5	6	7	0	H	7	8	9	10	11	2	H	5	6	7	8	9	4	H	3	4	5	6	7	 <p>H= 0+K+A</p> <table border="1"> <thead> <tr> <th>A</th> <th>K</th> <th>3</th> <th>4</th> <th>5</th> <th>6</th> <th>7</th> </tr> </thead> <tbody> <tr> <td>2</td> <td>H</td> <td>-1</td> <td>-2</td> <td>-3</td> <td>-4</td> <td>-5</td> </tr> <tr> <td>4</td> <td>H</td> <td>1</td> <td>0</td> <td>-1</td> <td>-2</td> <td>-3</td> </tr> </tbody> </table>	A	K	3	4	5	6	7	2	H	-1	-2	-3	-4	-5	4	H	1	0	-1	-2	-3
D	K	3	4	5	6	7																																																																									
0	H	17	18	19	20	21																																																																									
2	H	15	16	17	18	19																																																																									
4	H	13	14	15	16	17																																																																									
D	K	3	4	5	6	7																																																																									
0	H	7	8	9	10	11																																																																									
2	H	5	6	7	8	9																																																																									
4	H	3	4	5	6	7																																																																									
A	K	3	4	5	6	7																																																																									
2	H	-1	-2	-3	-4	-5																																																																									
4	H	1	0	-1	-2	-3																																																																									

MINIMUM REVEAL TABLE

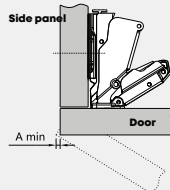

A	T	14	15	16	17	18	19	20	21	22	23	24	25	26
3	K	0.0	0.0	0.0	0.0	0.0	0.0	0.0	0.0	0.5	1.0	1.6	2.1	2.7
4	K	0.0	0.0	0.0	0.0	0.0	0.0	0.0	0.0	0.3	0.9	1.4	2.0	2.5
5	K	0.0	0.0	0.0	0.0	0.0	0.0	0.0	0.0	0.1	0.7	1.2	1.8	2.3
6	K	0.0	0.0	0.0	0.0	0.0	0.0	0.0	0.0	0.0	0.5	1.1	1.6	2.2
7	K	0.0	0.0	0.0	0.0	0.0	0.0	0.0	0.0	0.0	0.4	0.9	1.5	2.0

K = Boring distance

T = Door thickness

A = Minimum gap (A) for door with a door edge radius

l = Gap between door and panel

Note: above parameter based on the door edge is right-angle side, if the door is round corner edge, the parameter value will be reduce according to the edge size.

Hinge Quantity for Door

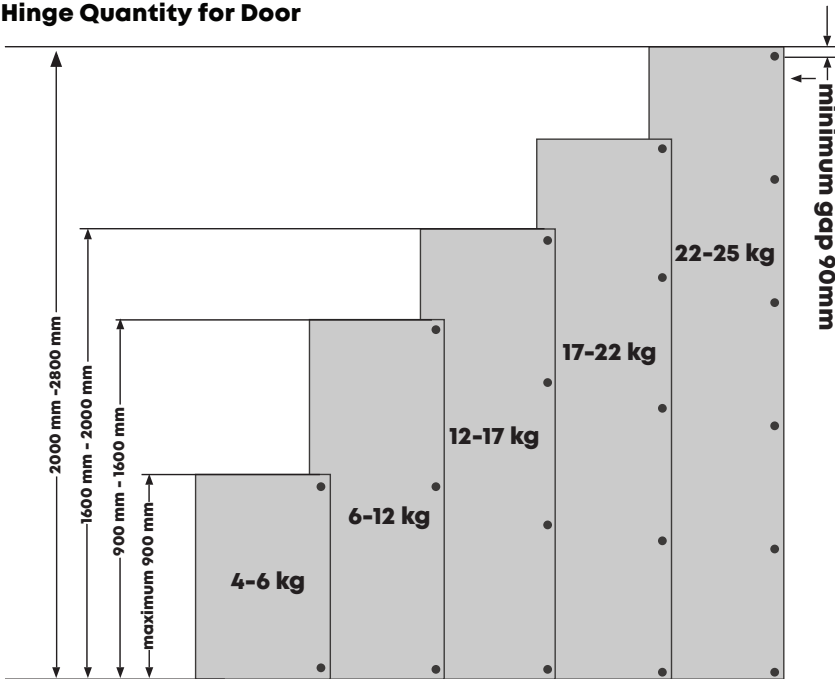

DRILLING FOR CUP

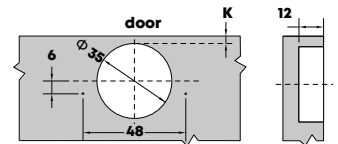

CUP INSTALLATION

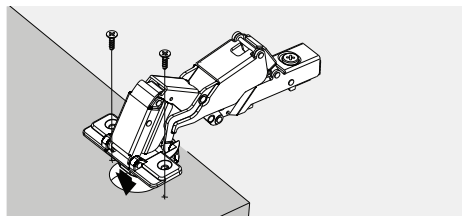
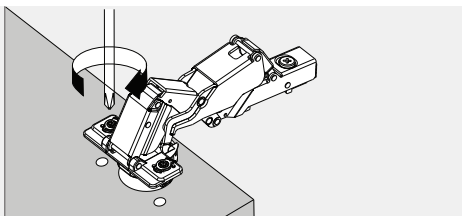
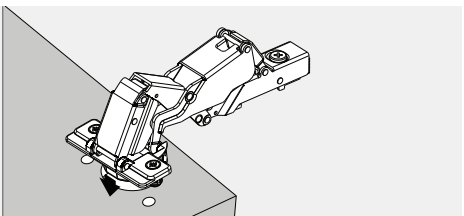
		
Screw on	Expanding	Knock-in
Wood screws	8mm expansive dowel	8mm dowel
	10mm expansive dowel	10mm dowel

HINGE ADJUSTMENT

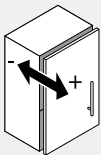
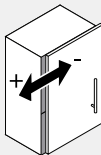
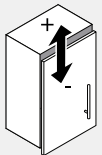
Depth Adjustment 	Overlay Adjustment 	Height Adjustment 
Rotate depth screw to adjust door gap. Adjust range : 3.8mm	Rotate lateral screw to increase or decrease door overlay. Adjust range : 6mm	Adjust the mounting plate on panel to adjust the door's height.

Notice: The reference adjustment range is the product design range, the actual size of the cabinet and the drilling method may have a certain impact on the parameters.



Soft close hinge for aluminum frame doors
 105° opening angle for alu frame thickness of 14-23mm
 Width of profile(P): 20-27mm
 Metal and zinc alloy material, Cu-Nickel/Cu-black nickel plated
 Integrated silent system
 Boss fixing screws are included

OVERLAY TABLE

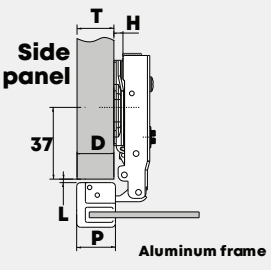
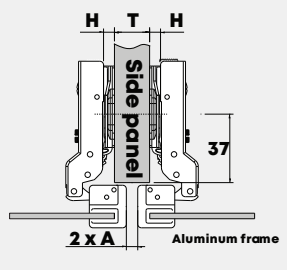
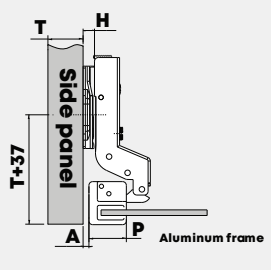
Full Overlay	Half Overlay	Inset																																																																																				
																																																																																						
$H = -2 + P - D$ <table border="1"> <thead> <tr> <th>D</th> <th>P</th> <th>19</th> <th>20</th> <th>21</th> <th>22</th> <th>23</th> </tr> </thead> <tbody> <tr> <td>0</td> <td>17</td> <td>18</td> <td>19</td> <td>20</td> <td>21</td> <td></td> </tr> <tr> <td>2</td> <td>15</td> <td>16</td> <td>17</td> <td>18</td> <td>19</td> <td></td> </tr> <tr> <td>4</td> <td>13</td> <td>14</td> <td>15</td> <td>16</td> <td>17</td> <td></td> </tr> </tbody> </table>	D	P	19	20	21	22	23	0	17	18	19	20	21		2	15	16	17	18	19		4	13	14	15	16	17		$H = -12 + P - D$ <table border="1"> <thead> <tr> <th>D</th> <th>P</th> <th>19</th> <th>20</th> <th>21</th> <th>22</th> <th>23</th> </tr> </thead> <tbody> <tr> <td>0</td> <td>7</td> <td>8</td> <td>9</td> <td>10</td> <td>11</td> <td></td> </tr> <tr> <td>2</td> <td>5</td> <td>6</td> <td>7</td> <td>8</td> <td>9</td> <td></td> </tr> <tr> <td>4</td> <td>3</td> <td>4</td> <td>5</td> <td>6</td> <td>7</td> <td></td> </tr> </tbody> </table>	D	P	19	20	21	22	23	0	7	8	9	10	11		2	5	6	7	8	9		4	3	4	5	6	7		$H = -20 + P + A$ <table border="1"> <thead> <tr> <th>A</th> <th>P</th> <th>19</th> <th>20</th> <th>21</th> <th>22</th> <th>23</th> </tr> </thead> <tbody> <tr> <td>0</td> <td>1</td> <td>0</td> <td>-1</td> <td>-2</td> <td>-3</td> <td></td> </tr> <tr> <td>2</td> <td>3</td> <td>2</td> <td>1</td> <td>0</td> <td>-1</td> <td></td> </tr> <tr> <td>4</td> <td>5</td> <td>4</td> <td>3</td> <td>2</td> <td>1</td> <td></td> </tr> </tbody> </table>	A	P	19	20	21	22	23	0	1	0	-1	-2	-3		2	3	2	1	0	-1		4	5	4	3	2	1	
D	P	19	20	21	22	23																																																																																
0	17	18	19	20	21																																																																																	
2	15	16	17	18	19																																																																																	
4	13	14	15	16	17																																																																																	
D	P	19	20	21	22	23																																																																																
0	7	8	9	10	11																																																																																	
2	5	6	7	8	9																																																																																	
4	3	4	5	6	7																																																																																	
A	P	19	20	21	22	23																																																																																
0	1	0	-1	-2	-3																																																																																	
2	3	2	1	0	-1																																																																																	
4	5	4	3	2	1																																																																																	

MINIMUM REVEAL TABLE

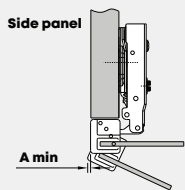

A	K	T	14	15	16	17	18	19	20	21	22
3	0.3	0.5	0.7	0.9	1.2	1.5	1.8	2.2	2.6		
4	0.3	0.5	0.7	0.9	1.1	1.4	1.8	2.1	2.5		
5	0.2	0.4	0.6	0.9	1.1	1.4	1.7	2.0	2.4		
6	0.2	0.4	0.6	0.8	1.1	1.3	1.6	2.0	2.4		
7	0.2	0.4	0.5	0.8	1.0	1.3	1.6	1.9	2.3		

K = Boring distance

T = Door thickness

A = Minimum gap (A) for door with a door edge radius

L = Gap between door and panel

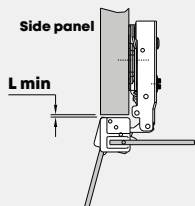

L	K	T	14	15	16	17	18	19	20	21	22
3	1.0	1.0	1.0	1.0	1.0	1.0	1.0	1.0	1.0		
4	1.0	1.0	1.0	1.0	1.0	1.0	1.0	1.0	1.0	1.2	
5	1.0	1.0	1.0	1.0	1.0	1.3	1.5	1.8	2.0		
6	1.0	1.3	1.5	1.8	2.0	2.3	2.5	2.8	3.0		
7	2.0	2.3	2.5	2.7	3.0	3.2	3.5	3.7	3.9		

Note: above parameter based on the door edge is right-angle side, if the door is round corner edge, the parameter value will be reduce according to the edge size.

DRILLING FOR CUP

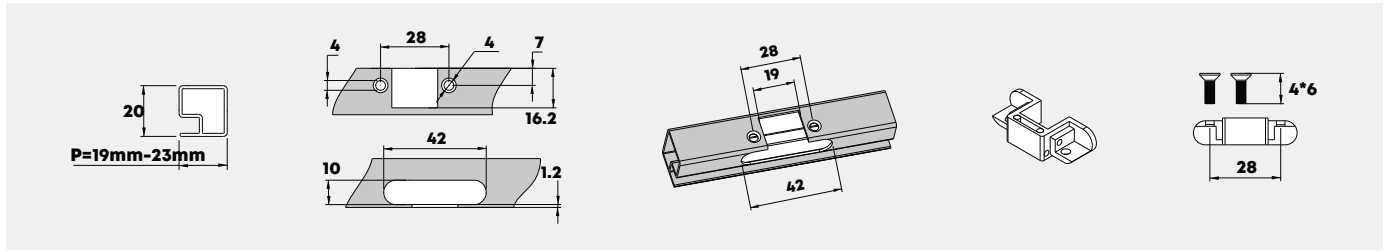

CUP INSTALLATION

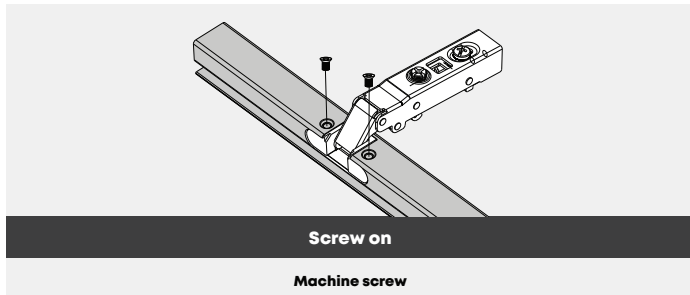

HINGE ADJUSTMENT

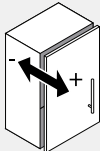
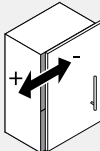
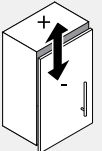
<p>Depth Adjustment</p> 	<p>Overlay Adjustment</p> 	<p>Height Adjustment</p> 
<p>Rotate depth screw to adjust door gap. Adjust range : 3.8mm (cam screw) 5mm (depth screw)</p>	<p>Rotate lateral screw to increase or decrease door overlay. Adjust range : 6mm</p>	<p>Adjust the mounting plate on panel to adjust the door's height.</p>



Synchronized Movement, Smooth and Integrated Soft Closing System

Quick and Easy drawer assembly and dismantling system

Loading Capacity 40 Kg

3D Locking Systems Adjustments

Full Extension undermount slides

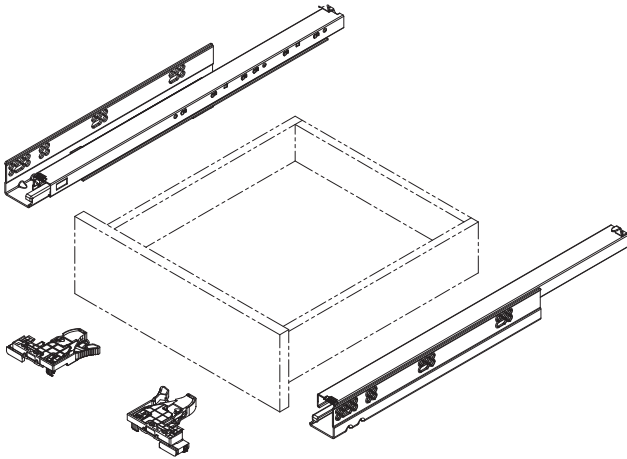

LuxeGlide Slides with Integrated Silent System

IDFS.400001	300 mm
IDFS.400002	350 mm
IDFS.400003	400 mm
IDFS.400004	450 mm
IDFS.400005	500 mm
IDFS.400006	550 mm

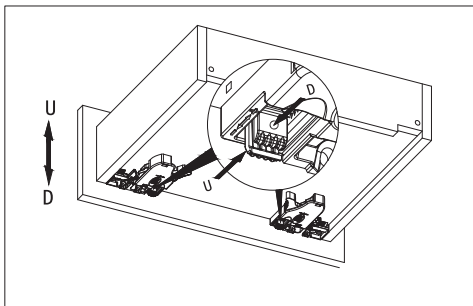

Height adjustment 0~+3mm

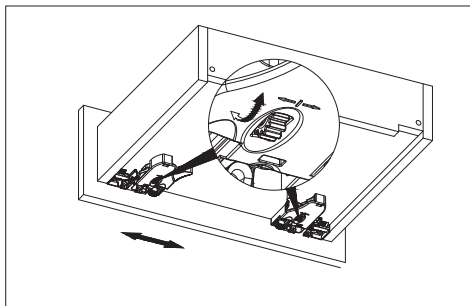

Side adjustment ± 1.5 mm

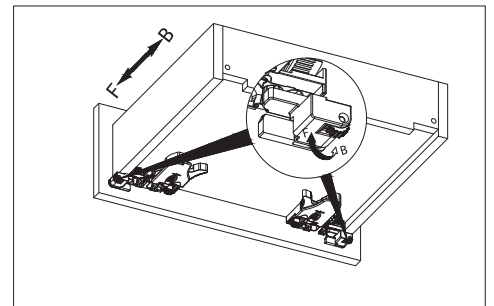

Depth (In and Out)
adjustment 0~3 mm

Installation for 16mm drawer side thickness

LW = Internal Cabinet Width SKW = Internal Drawer Width

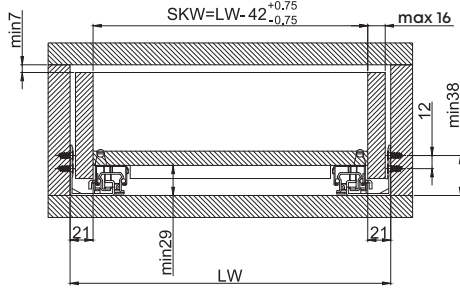

Installation for 19mm drawer side thickness

LW = Internal Cabinet Width SKW = Internal Drawer Width

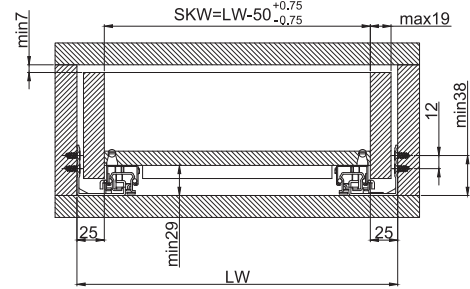

Installation Dimensions

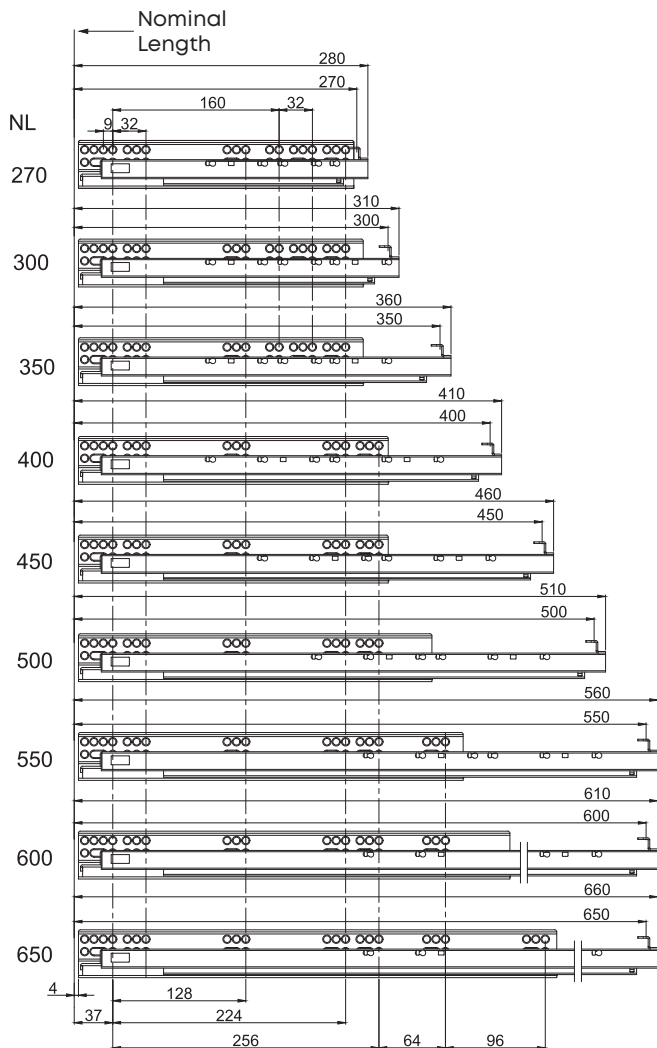

Drawer Dimensions

SKL = Drawer Length LT = Internal Cabinet Depth (min)

