

PRODUCT INFORMATION
OCT _ 2017



Progettiamo e realizziamo complementi d'arredo che aiutano a semplificare la vita quotidiana: oggetti funzionali caratterizzati da un elevato design.

We design and manufacture furnishing accessories which help make your life easier: highly functional objects with top class design.

Nous concevons et réalisons des compléments d'ameublement qui aident à simplifier la vie quotidienne : des objets fonctionnels, caractérisés par un design exceptionnel.

KITCHEN & LIVING

raccoglitori grande capacità
large capacity waste bins / collecteurs grande capacité

Linea 580 Plus **NEW**

03

Linea 570 Nava/Casiraghi design
Linea 571 Metal

07



BIN IT

raccoglitori ad estrazione frontale
pull-out waste bins / collecteurs à extraction frontale

Linea 222: Art.223 **NEW**

11

raccoglitori per cestone
waste bins for large drawer / collecteurs pour tiroirs

Sistema 9XL

13



TIDY IT

Linea COMBI™

19

BATHROOM & LAUNDRY

accessori per cassetto
drawer accessories / accessoires pour tiroir superieur

ONDA Vanity™

25



ONDA

accessori per cestone
large drawer accessories / accessoires pour grand tiroir

ONDA BOX

29

accessori per anta
door mounted accessories / accessoires pour porte

ONDA BINS **NEW**

30

portabiancheria sotto-top ad estrazione frontale
pull-out under-top laundry bins / panier à linge coulissant, fixation sous-comptoir

Linea UP Laundry **NEW**

31

portabiancheria ad estrazione frontale
pull-out laundry bins / panier à linge coulissant

Linea 560 Laundry

33

WHITES &
COLOURS

Linea 580 Laundry

35

portabiancheria per anta a ribalta
laundry bin for bottom hinged door / panier à linge pour porte à abattant

Linea BH Laundry

37

Linea 580 Plus

l'evoluzione della grande capacità
big capacity evolution
l'evolution de la grande capacité



- Disponibile per basi 300, 400, 450, 500, 600 mm
- Available for bases 300, 400, 450, 500, 600 mm
- Disponible pour bases 300, 400, 450, 500, 600 mm
- Capacità totale fino a 80 L
- Total capacity up to 80 L
- Capacité totale jusqu'à 80 L
- Secchi dotati di coperchio
- Bins equipped with lids
- Bacs munis de couvercle
- Tre altezze disponibili: H505, H463 e H298mm
- Three heights available: H505, H463 and H298mm
- Trois hauteurs disponibles: H505, H463 et H298mm
- Adatto a mobili con pareti laterali da 16 a 19mm di spessore
- Suitable for cabinets with sides thickness from 16 to 19mm
- Adapte pour meubles avec épaisseur laterale de 16 à 19mm
- Telaio in metallo con sponde in plastica. Supporti centrali in metallo
- Metal frame with plastic sides. Metal middle brackets
- Cadre en métal avec bords en plastique. Support central en métal

Linea 580 Plus Optionals

- Coperchio/ripiano ad incasso in metallo satinato o in plastica. Colore grigio orione.

- Built-in satin metal or plastic lid/shelf. Orion grey colour.

- Couvercle/étagère encastrable en métal brossé ou plastique. Couleur gris orion.

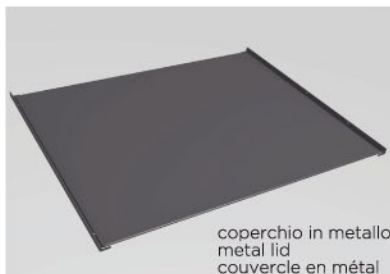

coperchio in metallo
metal lid
couvercle en métal

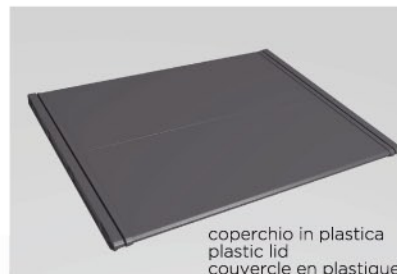

coperchio in plastica
plastic lid
couvercle en plastique

MYZYME™ ATOMIZING SYSTEM

- Grazie a un sistema brevettato di nebulizzazione, integrato al coperchio, il complesso enzimatico inodore a base di componenti naturali MYZYME™ elimina all'istante e permanentemente gli spiacevoli odori derivanti dalla raccolta dei rifiuti umidi e organici.

- MYZYME™, the odourless enzyme complex based on natural ingredients, eliminates unpleasant odours from moist and organic refuse immediately and permanently thanks to a patented misting system incorporated in the lid.

- MYZYME™, le complexe d'enzymes inodore à base de composantes naturelles, élimine instantanément et définitivement les mauvaises odeurs produites par les déchets ménagers et organiques grâce à un système breveté de nébulisation intégré dans le couvercle.

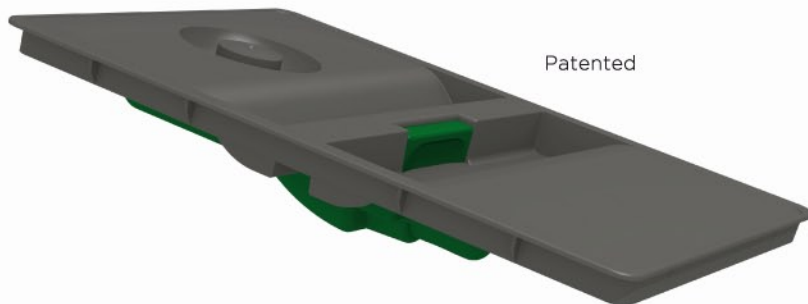

Patented

- Coperchio brevettato per la diffusione del liquido enzimatico MYZYME™.

- Patented lid with incorporated atomizing system for enzymatic liquid MYZYME™.

- Couvercle breveté avec système intégré de nébulisation pour liquide enzymatique MYZYME™.

MYZYME™ 100% ECO ANTI-ODOUR ENZYMES

- Il liquido enzimatico MYZYME™ è inodore e totalmente naturale. Nebulizzando il liquido MYZYME™ quotidianamente sui rifiuti organici è possibile eliminare permanentemente gli odori sgradevoli derivanti dalla raccolta differenziata.

- The MYZYME™ enzyme liquid is odorless and totally natural. Atomizing the MYZYME™ liquid daily on the organic waste permanently eliminates unpleasant odors caused by separate waste collection.

- Le liquide enzymatique MYZYME™ est inodore et totalement naturel. La vaporisation du liquide MYZYME™ quotidiennement sur les déchets organiques peut éliminer définitivement les odeurs désagréables causées par la collecte sélective des déchets.

MYZYME™ BOTTLE

- Il liquido enzimatico MYZYME™ è fornito in bottiglie da 1 litro ciascuna.

- The enzymatic liquid MYZYME™ is supplied in bottles of 1 litre capacity each.

- Le liquide enzymatique MYZYME™ est disponible en flacons avec capacité 1 litre chacun.



Linea 580 Plus

Colori/Colours/Couleurs:
Grigio orione/Orion grey/Gris orion

base 600 mm



580PL60C

D. 458
H. 505



TOT 80 L



10 min



600 mm

SOFT



580PL60A

D. 458
H. 463*



TOT 74 L



10 min



600 mm

SOFT



base 500 mm



580PL50C

D. 458
H. 505



TOT 80 L



10 min



500 mm

SOFT



base 450 mm



580PL45A

D. 458
H. 463*



TOT 58 L



10 min



450 mm

SOFT



base 400 mm



580PL40A

D. 458
H. 463*



TOT 58 L



10 min



400 mm

SOFT



base 300 mm



580PL30B

D. 458
H. 298



TOT 16 L



10 min



300 mm









SOFT



*Disponibili anche soluzioni H 298 mm / H 298 mm solutions also available/ Disponibles aussi solutions H 298 mm

Linea 580 Plus



| BASE mm | BASE mm | | |
|------------|---|---|---|
| | H. 505 mm | H. 463 mm | H. 298 mm |
| 300 | | | Art.580PL30B  TOT 16 L |
| 400 | | Art.580PL40A  TOT 58 L | Art.580PL40B  TOT 34 L |
| 450 | | Art.580PL45A  TOT 58 L | Art.580PL45B  TOT 34 L |
| 500 | Art.580PL50C  TOT 80 L | | |
| 600 | Art.580PL60C  TOT 80 L | Art.580PL60A  TOT 74 L | Art.580PL60B  TOT 50 L |

Optional / En option:

MYZYME™ ATOMIZING SYSTEM

- Disponibile per secchi da 17 e da 29 L.
- Available for 17 and 29 L bins.
- Disponible pour bacs de 17 et 29 L.



Optional / En option:

- coperchio ad incasso, in plastica o in metallo
- built-in plastic or metal lid
- couvercle encastrable, en plastique ou en métal

coperchio in metallo
metal lid
couvercle en métal

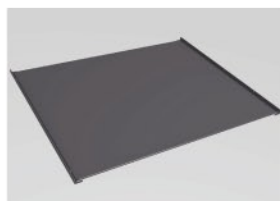

coperchio in plastica
plastic lid
couvercle en plastique

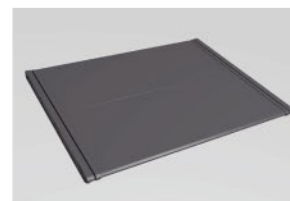



large capacity waste bins

Linea 570 Nava/Casiraghi design
Linea 571 Metal

Per sistemi cassetto Blum Legrabox®
For Blum Legrabox® drawer systems
Pour systèmes tiroir Blum Legrabox®



Nava Casiraghi Design

Linea 570 Nava/Casiraghi design Linea 571 Metal

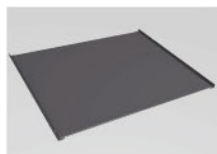

coperchio in metallo
metal lid
couverture en métal

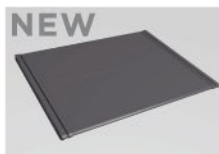

coperchio in plastica
plastic lid
couverture en plastique

- Forniti di coperchio/ripiano ad incasso in metallo satinato o in plastica. Colore grigio orione.

- Supplied with built-in satin metal or plastic lid/shelf. Orion grey colour.

- Equipés avec couvercle/étagère encastrable en métal brossé ou plastique. Couleur gris orion.

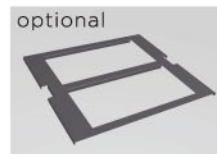

optional

- Cover in alluminium satinato, colore grigio orione.

- Satin aluminium cover, orion grey colour.

- Couverture en aluminium brossé, couleur gris orion.

Linea 570 Nava/Casiraghi design

- L'elegante sistema in legno ed alluminio, disegnato da Paolo Nava e Fabio Casiraghi, consente di sfruttare al meglio lo spazio all'interno del cassetto creando un solido appoggio per i capienti raccoglitori e ricavando due pratici vani laterali portaoggetti (ideali per contenere spugne, rotoli di sacchetti, guanti, prodotti per la pulizia, ecc.). Studiato per sistemi cassetto Blum Legrabox® nelle altezze M (90.5mm), K (128.5mm) e C (177mm), profondità 500mm.

- The elegant wooden and aluminum system, designed by Paolo Nava and Fabio Casiraghi, allows to make the most of the space inside the drawer by creating a solid support for the big hanging bins and obtaining two practical side storage compartments (ideal for storing sponges, rolls of bags, gloves, cleaning products, etc.). Designed for Blum Legrabox® drawer systems in M (90.5mm), K (128.5mm) and C (177mm) heights, 500mm depth.

- L'élégant système de bois et aluminium, conçu par Paolo Nava et Fabio Casiraghi, permet de tirer le meilleur parti de l'espace intérieur du tiroir en créant un support solide pour les bacs grande capacité et permettant d'obtenir deux pratiques compartiments de rangement latéraux (idéals pour stocker des éponges, rouleaux de sacs, gants, produits de nettoyage, etc.). Conçu pour les systèmes de tiroirs Blum Legrabox® en hauteur M (90.5mm), K (128.5mm) et C (177mm), 500mm de profondeur.

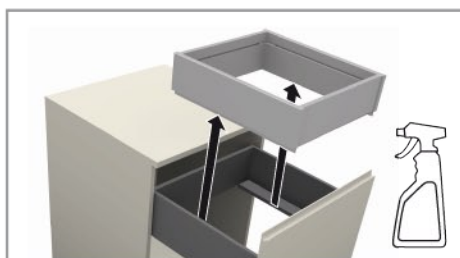

- La cornice di supporto in alluminio è facilmente estraibile per agevolare la pulizia del prodotto.

- The aluminum support frame can be removed to facilitate product cleaning.

- Le châssis de support en aluminium peut être enlevé pour un nettoyage facile du produit.

Linea 571 Metal



- Telaio in metallo verniciato color grigio orione. Studiato per sistemi cassetto Blum Legrabox® altezza C (177mm), profondità 500mm.

- Orion grey painted metal frame. Designed for Blum Legrabox® drawer systems C height (177mm), 500mm depth.

- Cadre en metal peint en gris orion. Conçu pour systèmes de tiroirs Blum Legrabox® hauteur C (177mm), 500mm de profondeur.

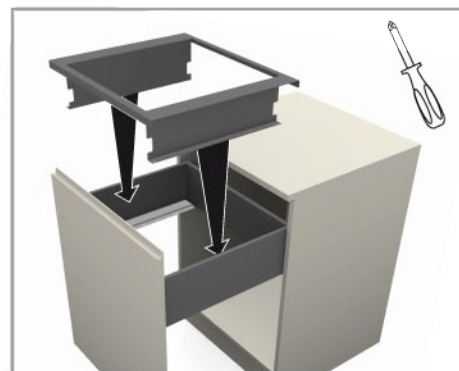

- Montaggio facile e veloce.

- Quick and easy installation.

- Installation rapide et facile.

Linea 570 Nava/Casiraghi design

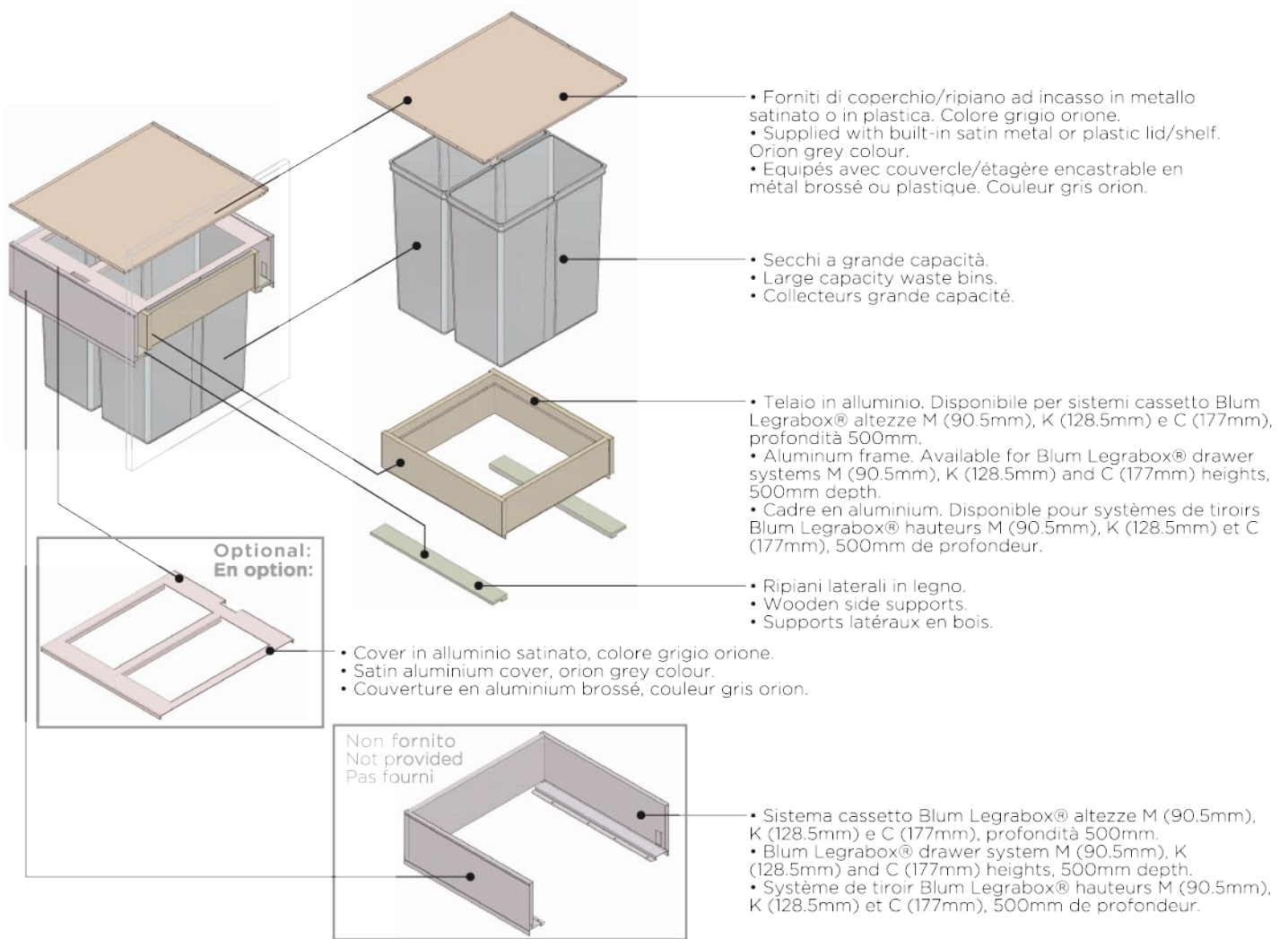

• I codici indicati in tabella si riferiscono agli articoli adatti al sistema cassetto Blum Legrabox® altezza M.
• The codes shown in the table refer to the items suitable for Blum Legrabox® drawer system M height.
• Les codes indiqués dans le tableau se réfèrent aux références propres au système de tiroirs Blum Legrabox® hauteur M.



Coperchi manuali non inclusi
Manual lids not included
Couvercles manuels pas inclus

| BASE mm | H. 505 mm | H. 463 mm |
|---------|--|--|
| 400 | | <p>TOT 37 L</p> <p>Art. 570G44050A</p> |
| 450 | | <p>TOT 37 L</p> <p>Art. 570G44550A</p> |
| 500 | | <p>TOT 58 L</p> <p>Art. 570G45050A</p> |
| 600 | <p>TOT 80 L</p> <p>Art. 570G46050C</p> | |

large capacity waste bins

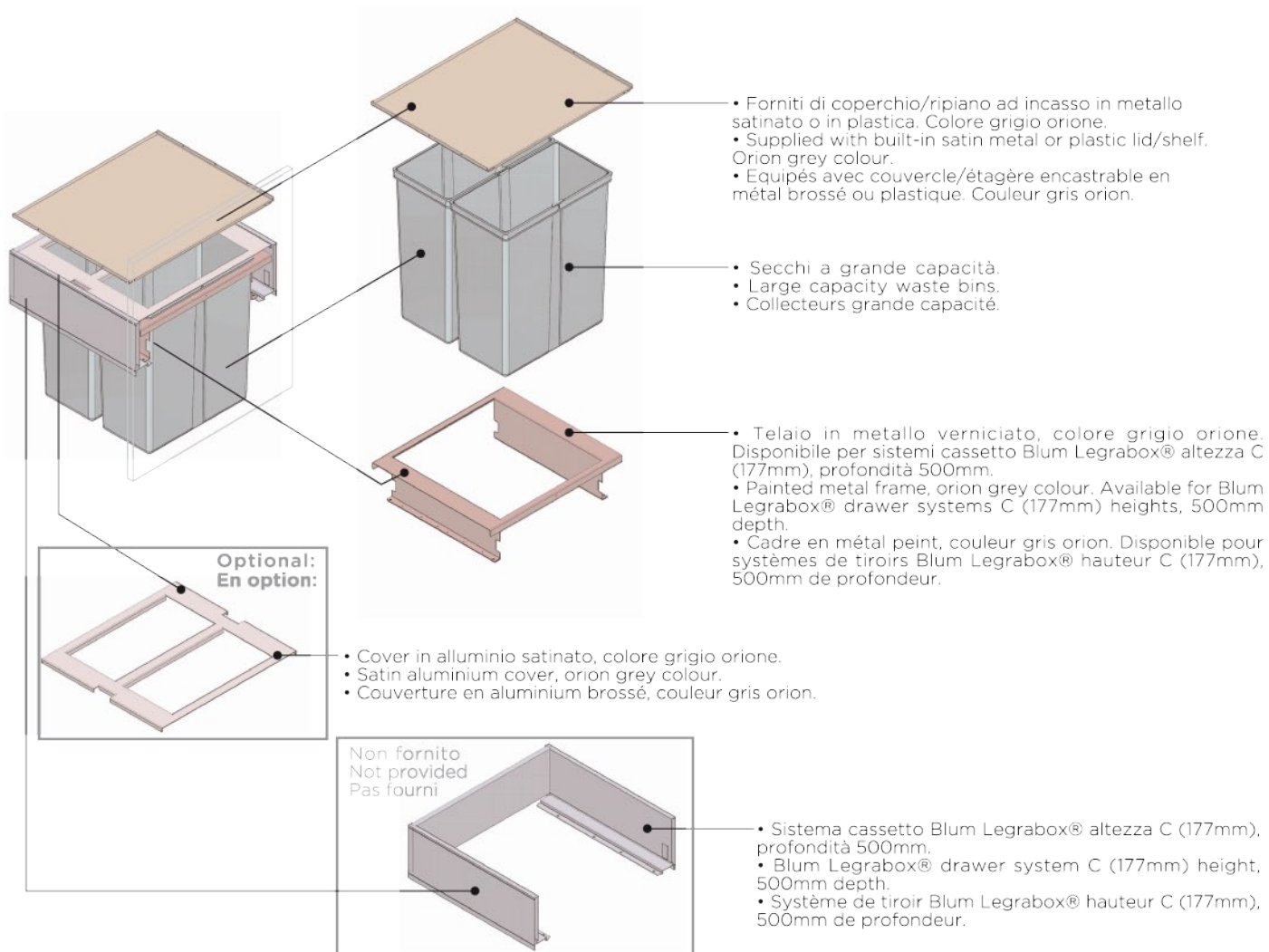
Linea 571 Metal



| BASE mm | H. 505 mm | H. 463 mm |
|------------|---|--|
| 450 | |  <p>Art. 571G44550A TOT 37 L</p> |
| 600 |  <p>Art. 571G46050C TOT 80 L</p> | |

Coperchi manuali non inclusi
Manual lids not included
Couvercles manuels pas inclus

Art 223
raccoglitore dotato di 3 secchi da 10L
3 x 10L bins container
collecteur avec 3 x 10L bacs



Contenitore per la raccolta differenziata, ideale per spazi ridotti (base min. 300 mm). Dimensioni compatte ed installazione rapida sotto qualsiasi tipo di lavello.

Container for separate waste collection, the ideal solution for small spaces (minimum base 300 mm). Compact dimensions and quick installation under every kind of sink.

Collecteur pour la collecte sélective, la solution idéale pour les espaces réduits (base min. 300 mm). Dimensions compactes et installation rapide sous tout type d'évier.

pull-out waste bins
Linea 222



Dotato di speciali guide ad estrazione totale.
Equipped with special full extension slides.
Équipé avec spéciales glissières à extraction totale.



Coperchio studiato per facilitare l'apertura e la chiusura in presenza di rifiuti sporgenti.
The lid has been studied to facilitate the opening and closing in the presence of jutting out waste.
Le couvercle est étudié pour faciliter l'ouverture et la fermeture en présence de déchets en saillie.



Il coperchio consente l'appoggio di guanti, spugne e piccoli oggetti.
The lid allows the rest of gloves, sponges and small objects.
Le couvercle permet l'appui de gants, éponges et petits objets.



Coperchio facilmente rimovibile per semplificarne la pulizia.
The lid can be easily removed for a better cleaning.
Le couvercle est aisément amovible pour en simplifier le nettoyage.

223

Colori/Colours/Couleurs:
Grigio / Grey / Gris

3
BINS

W. 255
D. 450
H. 400



TOT 30 L



5 min



min. 300 mm



waste bins for large drawer
Sistema 9XL

Secchi extra large
Extra large bins
Seaux extra larges



Colori/Colours/Couleurs:
Grigio orione/Orion grey/Gris orion

- Secchi molto capienti per agevolare la raccolta differenziata dei rifiuti più ingombranti (bottiglie di plastica e vetro, lattine, cartone per alimenti...).
- Extra large bins to make separate collection of bulky refuse easier (glass and plastic bottles, cans, food paperboard...).
- Bacs de grande capacité pour faciliter la collecte sélective des déchets les plus encombrants (bouteilles en verre et plastique, canettes, carton à usage alimentaire...).



H 277 mm

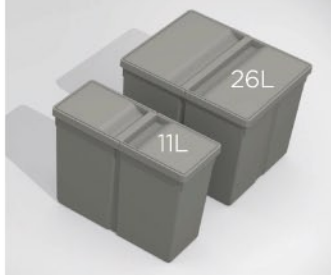

H 209 mm



- Secchi disponibili in due altezze e in due larghezze differenti.
- Bins available in two different sizes and heights.
- Bacs disponibles en deux différents largeurs et hauteurs.

- Modularità nella posizione dei raccoglitori. Possibilità di affiancare secchi con dimensioni differenti per poter ottimizzare gli spazi all'interno dei cestoni.
- Modular arrangements of the bins. Bins of different dimensions can be placed together to optimise the use of space inside the kitchen drawers.
- Positionnement modulaire des conteneurs. Possibilité de disposer des seaux de différentes dimensions un à côté de l'autre afin d'optimiser l'espace à l'intérieur des tiroirs.

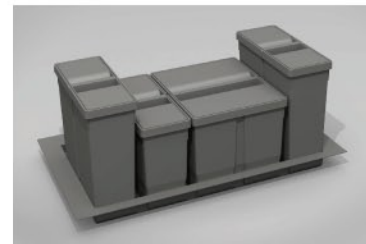
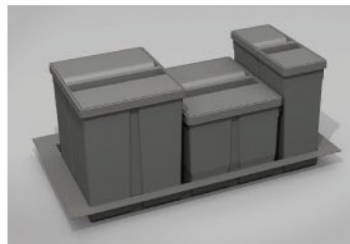

esempi di composizione per cassetto da 900 mm.
exemples of some 900 mm drawer combinations.
exemples de compositions pour tiroir 900 mm.

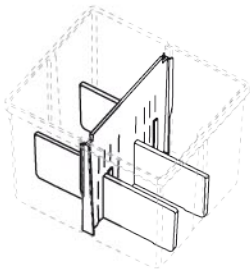

- Portadetersivi con separatori regolabili. Utile per trasportare ed organizzare ordinatamente i principali prodotti per la pulizia della casa. Il separatore **centrale** può essere utilizzato anche come divisorio consentendo di ottenere due **vani** per la raccolta differenziata all'interno di un unico secchio.
- Detergent-holder with adjustable dividers. Useful for carrying and organising the main household cleaning products. The central divider can also be used as a partition allowing to obtain two compartments for separate collection **within** a single bucket.
- Porte-détersifs avec séparateurs réglables. Pratique pour transporter et organiser les principaux produits de nettoyage ménager. Le séparateur **central** peut également être utilisé comme une partition permettant d'obtenir **deux** compartiments pour la collecte séparée dans un seul seau.



- Optional:
coperchio automatico dotato di sistema di fissaggio ai fianchi interni del mobile.
- Optional:
automatic lid equipped with fixing system to the sides of the cabinet.
- En option:
couverture automatique avec système de fixation sur les côtés du meuble.

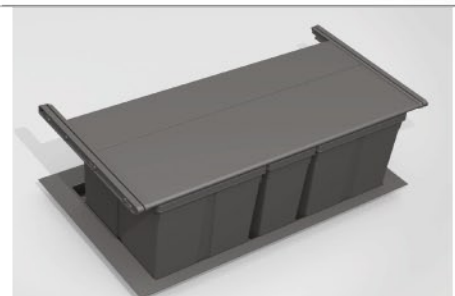



**MYZYME™
ATOMIZING
SYSTEM**

- Grazie a un sistema brevettato di nebulizzazione, integrato al coperchio, il complesso enzimatico inodore a base di componenti naturali MYZYME™ elimina all'istante e permanentemente gli spiacevoli odori derivanti dalla raccolta dei rifiuti umidi e organici.
- MYZYME™, the odourless enzyme complex based on natural ingredients, eliminates unpleasant odours from moist and organic refuse immediately and permanently thanks to a patented misting system incorporated in the lid.
- MYZYME™, le complexe d'enzymes inodore à base de composantes naturelles, élimine instantanément et définitivement les mauvaises odeurs produites par les déchets ménagers et organiques grâce à un système breveté de nébulisation intégré dans le couvercle.



waste bins for large drawer

Sistema 9XL

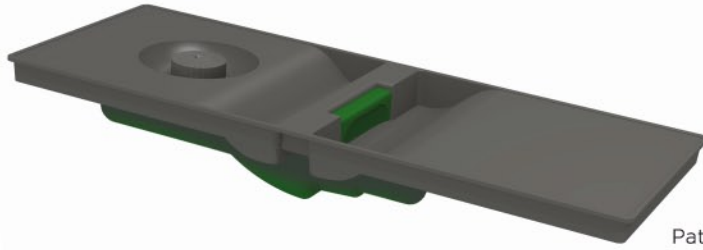

Patented

MYZYME™ ATOMIZING SYSTEM

- Coperchio brevettato per la diffusione del liquido enzimatico MYZYME™. Il coperchio può essere fornito sia separatamente come optional sia incluso nella confezione dei raccoglitori.
- Patented lid with incorporated misting system for enzymatic liquid MYZYME™. The lid may be provided either separately as an option or included in the package with the collectors.
- Couvercle breveté avec système intégré de nébulisation pour liquide enzymatique MYZYME™. Le couvercle peut être fourni séparément en option ou inclus dans le module avec les collecteurs.



MYZYME™
100% ECO
 ANTI-ODOUR ENZYMES

- Il liquido enzimatico MYZYME™ è inodore e totalmente naturale. Nebulizzando il liquido MYZYME™ quotidianamente sui rifiuti organici è possibile eliminare permanentemente gli odori sgradevoli derivanti dalla raccolta differenziata.
- The MYZYME™ enzyme liquid is odorless and totally natural. Atomizing the MYZYME™ liquid daily on the organic waste permanently eliminates unpleasant odors caused by separate waste collection.
- Le liquide enzymatique MYZYME™ est inodore et totalement naturel. La vaporisation du liquide MYZYME™ quotidiennement sur les déchets organiques peut éliminer définitivement les odeurs désagréables causées par la collecte sélective des déchets.



Colori/Colours/Couleurs:
Grigio orione/Orion grey/Gris orion

BASE
mm



Vassoio / Tray / Plateau
(min-max) mm

H. 277

H. 209

1200

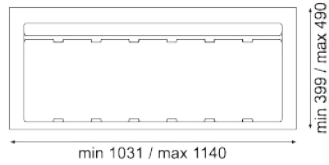

TOT 89 L



TOT 69 L

1000

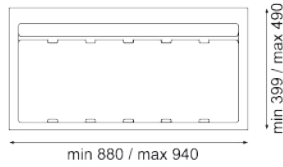

TOT 74 L



TOT 58 L

900

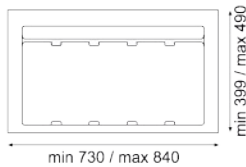

TOT 63 L



TOT 49 L

800 - 700

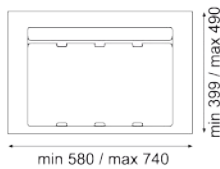

TOT 48 L



TOT 38 L

600

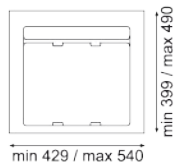

TOT 37 L



TOT 29 L

500 - 450 - 400



TOT 22 L



TOT 18 L

Sistema 9XL Optionals



- Coperchio automatico dotato di sistema di fissaggio ai fianchi interni del mobile.
- Automatic lid equipped with fixing system to the sides of the cabinet.
- Couvercle automatique avec système de fixation sur les côtés du meuble.

MYZYME™ ATOMIZING SYSTEM

- Coperchio brevettato per la diffusione del liquido enzimatico MYZYME™.
- Patented lid with incorporated atomizing system for enzymatic liquid MYZYME™.
- Couvercle breveté avec système intégré de nébulisation pour liquide enzymatique MYZYME™.

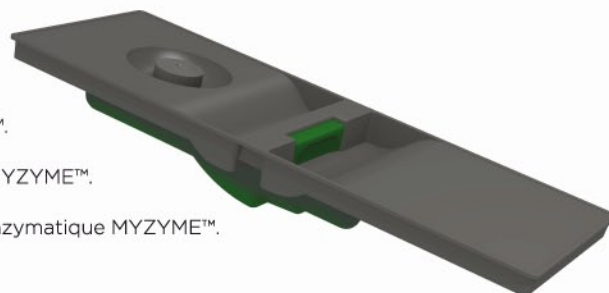

MYZYME™ BOTTLE

- Il liquido enzimatico MYZYME™ è fornito in bottiglie da 1 litro ciascuna.
- The enzymatic liquid MYZYME™ is supplied in bottles of 1 litre capacity each.
- Le liquide enzymatique MYZYME™ est disponible en flacons avec capacité 1 litre chacun.



cutlery trays

Linea COMBI™

NEW





Linea Combi è la nuova linea di portaposate modulari di **Gollinucci** pensata per consentire la migliore combinazione tra estetica e ottimizzazione degli spazi all'interno del cassetto. I moduli della Linea Combi sono dotati di **un'aletta di finitura laterale che consente di inserire il portaposate anche in una porzione di cassetto**, offrendo la possibilità di accessorizzare la restante parte di cassetto a piacere. L'aletta di finitura è stata studiata per creare un effetto di continuità con il cassetto donando un aspetto gradevole e lineare all'insieme. I moduli disponibili consentono di creare numerose varianti di prodotto adattabili a differenti larghezze di cassetto. Combi è resa ancora più funzionale dalla possibilità di accessorizzare i moduli con portacoltelli e tagliere. Per creare un legame armonioso tra i diversi vani della cucina, il linguaggio estetico della Linea Combi usa le stesse geometrie dei raccoglitori per raccolta differenziata "Sistema 9XL".

Combi is the new line of modular cutlery trays by **Gollinucci** designed to create the best mix of aesthetics and space optimisation inside a drawer. The modules are fitted **with a side wing so that the cutlery tray can even be inserted into a portion of drawer**, giving you the possibility to accessorise the remaining part of the drawer the way you want. The wing has been designed to create a continuity effect with the drawer giving an overall pleasant and linear look. The modules available create numerous variations of product adaptable to different drawer widths. Combi is made even more functional by the possibility to accessorize the modules with knife holders and chopping board.

To create a harmonious connection among the different niches in the kitchen, the aesthetic language of Combi uses the same shapes of the "Sistema 9XL" collectors for separate waste collection.

La Ligne Combi est la nouvelle ligne de range-couverts modulaires de **Gollinucci** pensée pour permettre la meilleure combinaison possible entre esthétique et optimisation des espaces à l'intérieur du tiroir. Les modules de la Ligne Combi sont **pourvus d'une ailette de finition latérale qui permet d'insérer le range-couverts également dans une partie du tiroir**, en offrant ainsi la possibilité d'accessoiriser la partie restante à votre convenance. L'aillette de finition a été étudiée pour créer un effet de continuité avec le tiroir tout en conférant un aspect agréable et linéaire à l'ensemble. Les modules disponibles permettent de créer de nombreuses variantes du produit adaptables à différentes largeurs de tiroir. La possibilité d'accessoiriser les modules avec range-couteaux et planche à découper font de Combi une ligne encore plus fonctionnelle.

Pour créer un lien harmonieux entre les différentes parties de la cuisine le langage esthétique de la Ligne Combi utilise les mêmes géométries des récipients pour la collecte sélective "Système 9XL".

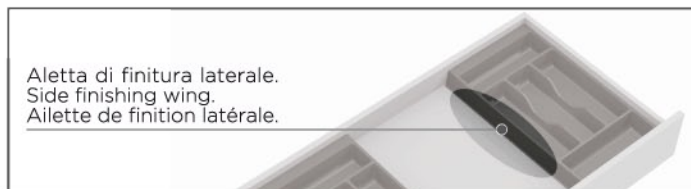

Aletta di finitura laterale.
Side finishing wing.
Ailette de finition latérale.



Colori/Colours/Couleurs:
Grigio orione/Orion grey/Gris orion

Imballo / Packing / Conditionnement
25 pz pcs

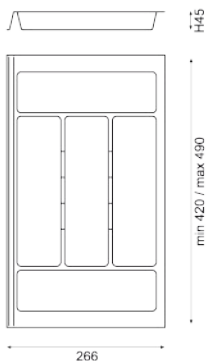

Elemento adatto a posizionamento al fianco del cassetto
Element to be positioned on the drawer side / Élément positionnable avec côté du tiroir.

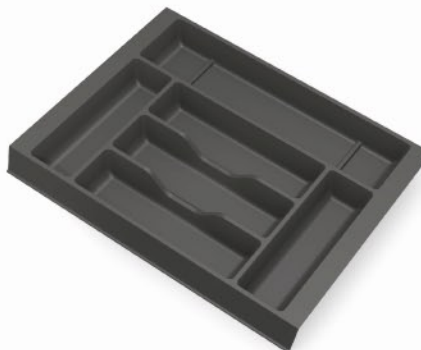
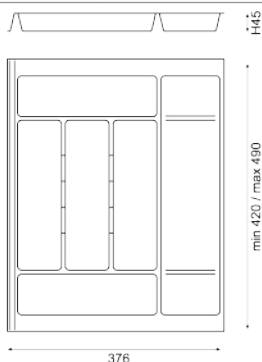

710



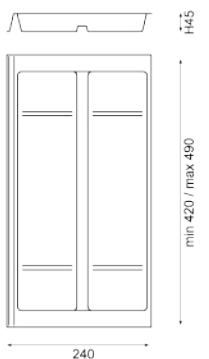

714

Optional
 or 
Art. 716 Art. 717



715

Optional
 or 
Art. 716 Art. 717

Elemento adatto a posizionamento al centro del cassetto
Element to be positioned in the middle of the drawer / Élément positionnable au centre du tiroir.

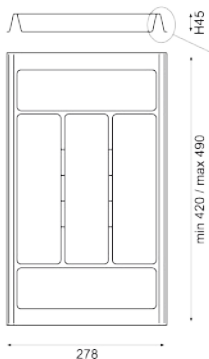

Aletta di finitura laterale presente su entrambi i lati.
Side finishing wing on both sides.
Ailette de finition latérale sur les deux côtés.



712



716

Porta coltelli in faggio
Adatto ad art.
714, 715

Knife block made of beech wood
Suitable for item:
714, 715

Porte-couteaux en hêtre
Indiqué pour les réf.
714, 715



Imballo / Packing / Conditionnement
5 pz pcs

717

Tagliere in polietilene
Adatto ad art.
714, 715

Chopping board made of polyethylene
Suitable for item:
714, 715

Planche à découper en polyéthylène
Indiqué pour les réf.
714, 715



Imballo / Packing / Conditionnement
5 pz pcs



Alcuni esempi di COMBINazioni nei cassetti
Some examples of COMBINations in the drawers
Quelques exemples de COMBINaisons dans les tiroirs

710 

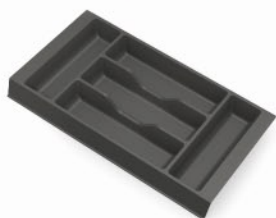

712 



714 

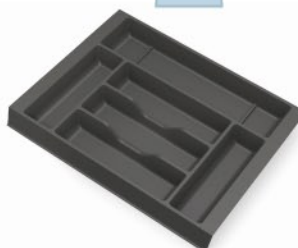

715 



base 400 mm

710

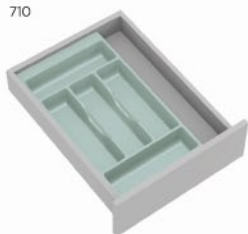

715



base 450 mm

710

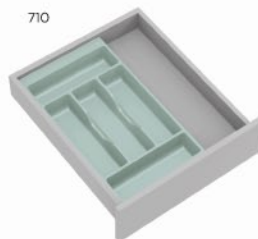

715



base 500 mm

714

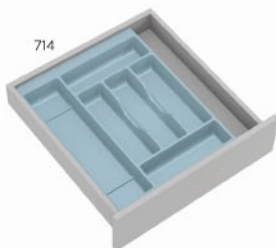

710

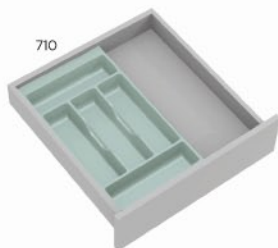

715



base 600 mm

714



715

710

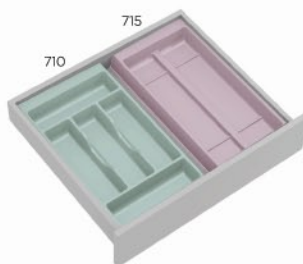

712

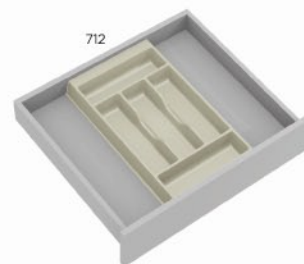



base 800 mm

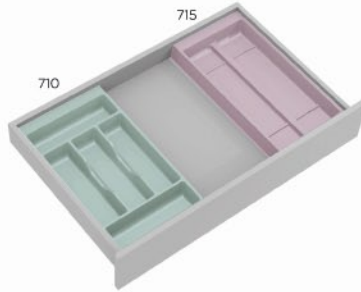
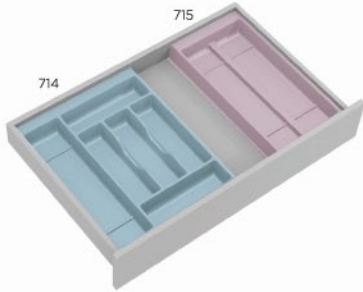

base 900 mm

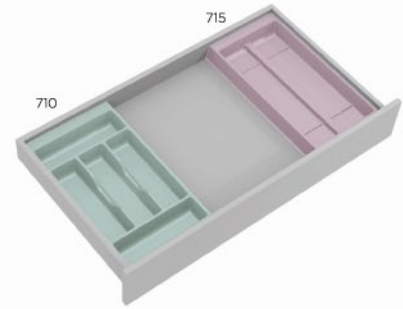
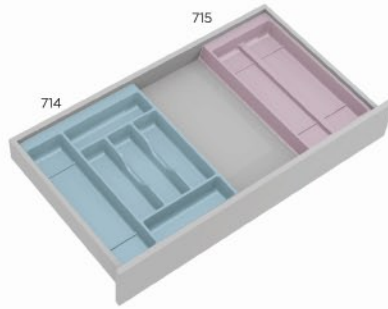
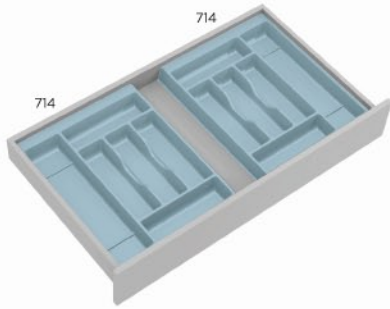

base 1000 mm

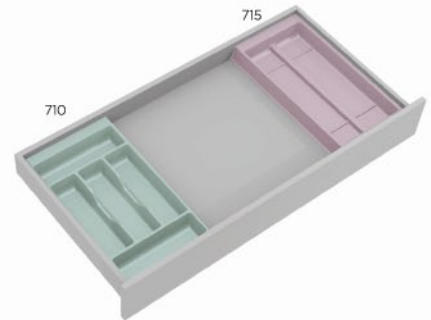
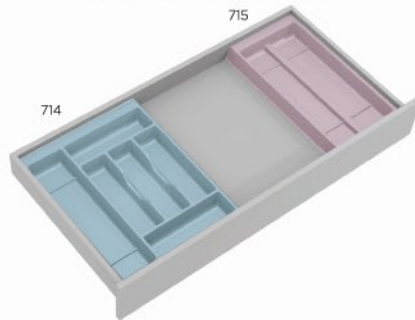
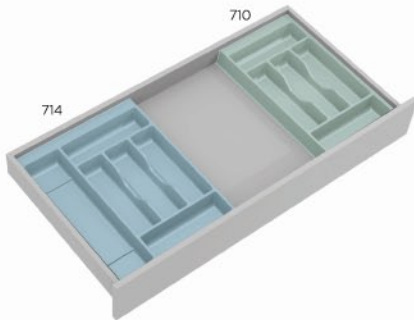

base 1200 mm

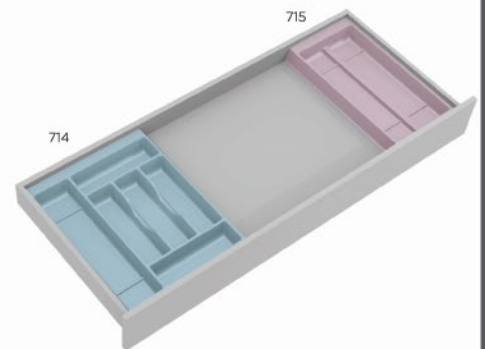
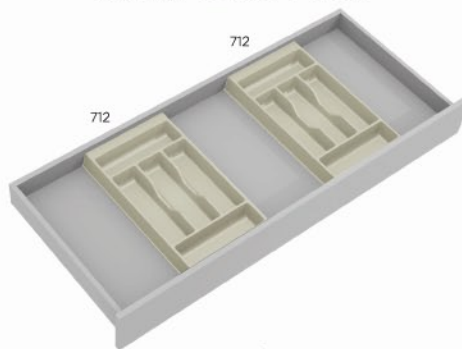
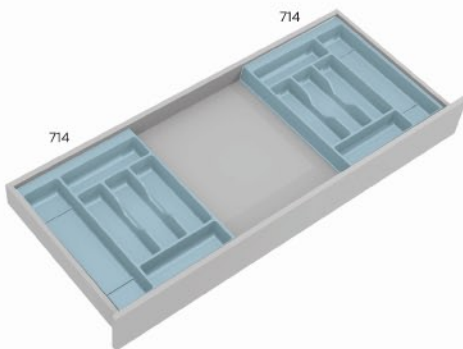



drawer accessories

ONDA Vanity™



ONDA Vanity™

La Linea Onda si arricchisce con **nuove vasche** dotate di accessori multifunzione removibili. Le vasche sono disponibili in diverse misure per adattarsi alle varie dimensioni dei cassetti.

ONDA Line is joined by **new trays** supplied with removable multi-function accessories. The trays are available in different sizes to suit the different drawer dimensions.

La Ligne ONDA s'enrichit de **nouvelles vasques** fournies avec accessoires amovibles multifonctionnels. Les vasques sont disponibles en plusieurs tailles pour s'adapter aux différentes dimensions des tiroirs.

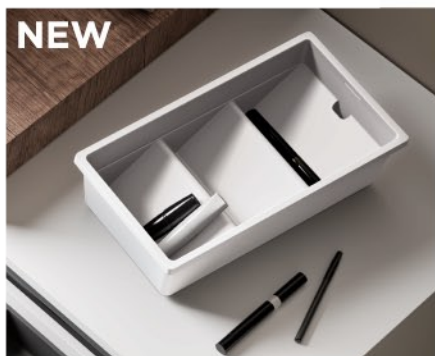

Scatola porta-oggetti
Storage box
Boîtes de rangement

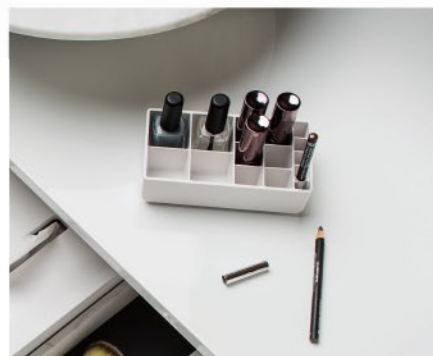

Portacosmetici
Cosmetic holder
Boite range-cosmétiques



Vaschetta
Small tray
Bac porte-objets



Scatolina con coperchio
Small box with lid
Petite boîte avec couvercle



Colori/Colours/Couleurs:
Bianco/White/Blanc
Grigio orione/Orion grey/Gris orion

large drawer accessories

ONDA Vanity™

Per Profondità
For Drawer Depth
Pour Profondeur

450 mm

CA45VL

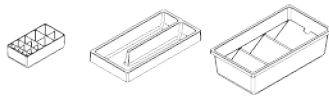
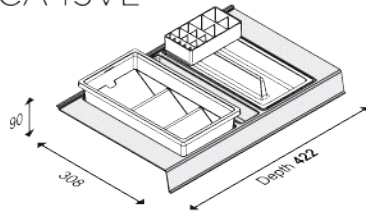

CA45VM

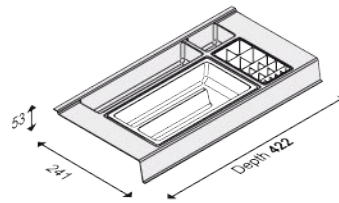

CA45SP

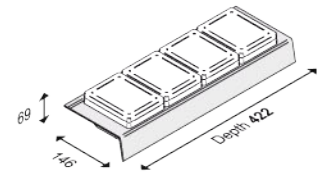

Per Profondità
For Drawer Depth
Pour Profondeur

400 mm

CA40VL

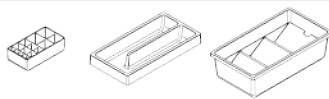
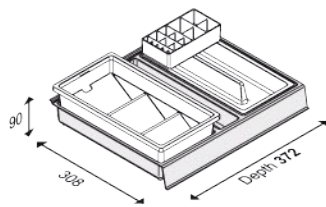

CA40VM

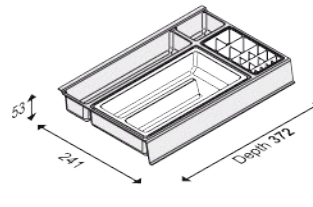

CA40SP

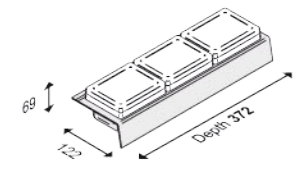

Per Profondità
For Drawer Depth
Pour Profondeur

350 mm

CA35VL

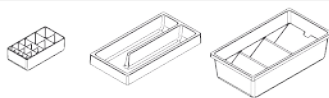
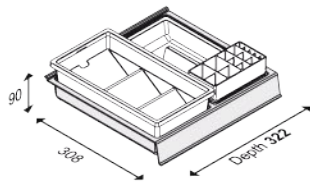

CA35VM

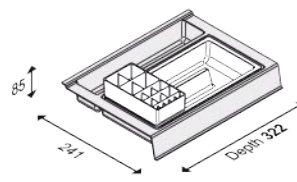

CA35SP

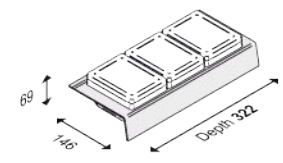

Per Profondità
For Drawer Depth
Pour Profondeur

270 mm

CA27VL

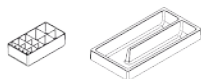
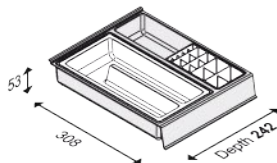

CA27VM

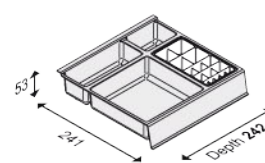

CA27SP

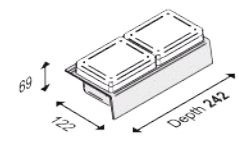

Possano essere forniti a misura (su richiesta) / Customized dimensions on request / Fournis à dimension (sur demande)

(Profondità 400mm / Drawer Depth 400mm / Profondeur 400mm)

base 600 mm

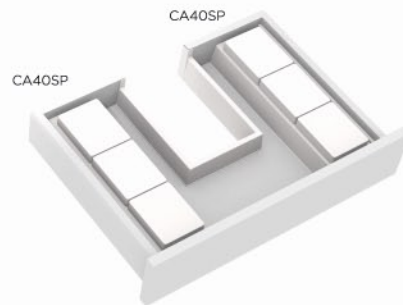

base 800 mm

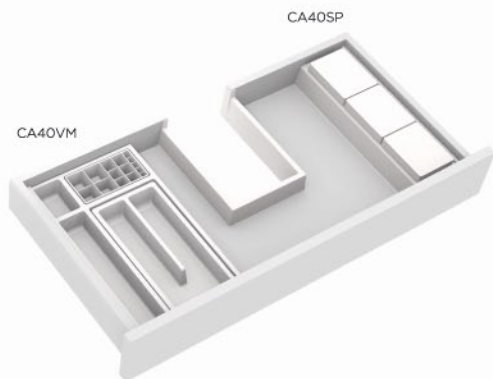

base 900 mm

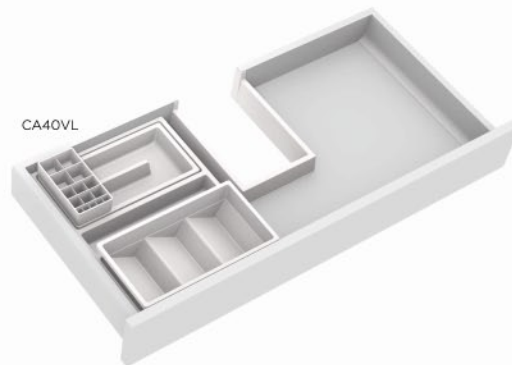

base 1000 mm

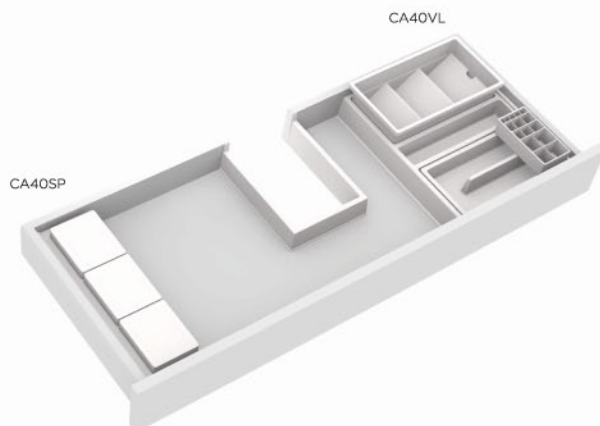
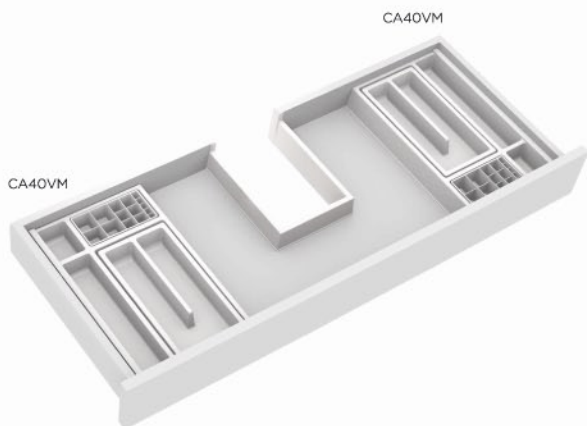

ONDA BOX



Scatole multi-uso removibili e trasportabili all'esterno del cestone per un pratico uso anche sul top. Le scatole più piccole sono studiate per l'inserimento nella scatola più grande e sono provviste di coperchio portaoggetti.

Multipurpose removable boxes for handy use also on worktops. The smaller boxes are designed to fit inside the largest box and are equipped with a practical storage lid.

Boîtes multi-usages amovibles et transportables à l'extérieur du tiroir pour une utilisation pratique sur le top également. Les boîtes les plus petites ont été conçues pour être introduites dans la boîte plus grande et sont équipées d'un couvercle de rangement pratique.

Colori/Colours/Couleurs:
Bianco/White/Blanc
Grigio orione/Orion grey/Gris orion

ONDA BOX

complete box
W. 254
D. 254
H. 210

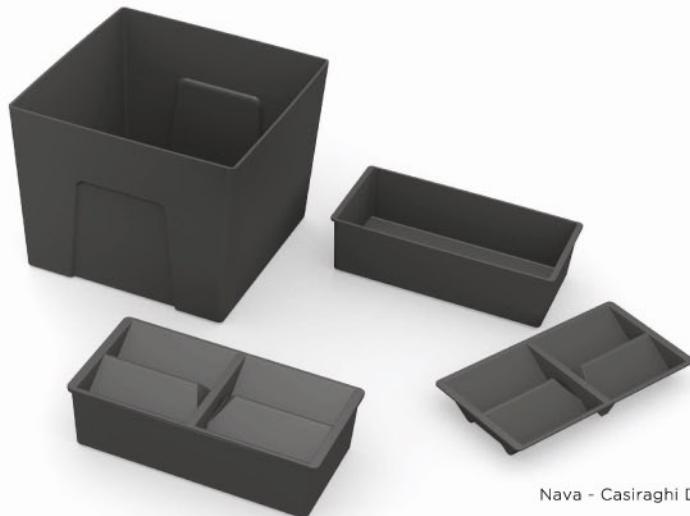
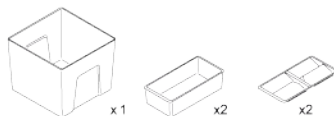

Nava - Casiraghi Design

ONDA BINS



Pratico raccoglitore bagno dotato di supporto per fissaggio all'anta.
Il prodotto include un kit di montaggio che consente il fissaggio sia con nastro biadesivo che con viti.

Practical bathroom collector with support for door mounting.
The product includes a mounting kit that allows the fixation with double-sided tape or with screws.

Collecteur pratique pour la salle de bains avec support pour fixation sur porte.
Le produit inclut un kit de montage qui permet à la fois le montage avec ruban adhésif double face ou avec des vis.

Colori/Colours/Couleurs:
Bianco/White/Blanc
Grigio orione/Orion grey/Gris orion

ATANPAAA

ATANPABA

nuovo supporto
new support
nouveau support
NEW

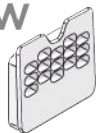

+

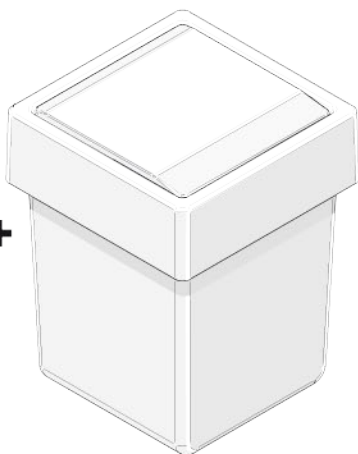

Raccoglitore con
coperchio basculante.
Bin with swivelling lid.
Boîte à déchets avec
couvercle basculant.

W. 174
D. 176
H. 229



TOT 5 L



2 min

nuovo supporto
new support
nouveau support
NEW

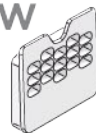

+

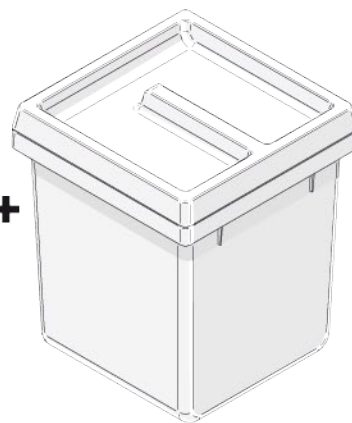

Raccoglitore con
coperchio manuale.
Bin with manual lid .
Boîte à déchets avec
couvercle manuel.

W. 170
D. 174
H. 202



TOT 5 L



2 min

Linea UP Laundry

fissaggio sottotop
under-top installation
installation sous-comptoir

NEW

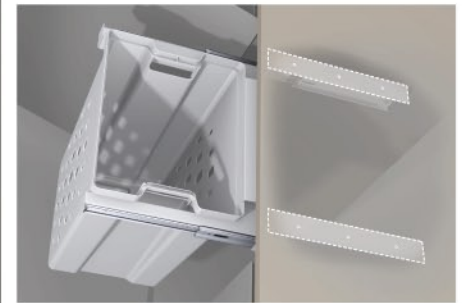

- Fissaggio alla parte superiore, non necessita di fissaggio ai fianchi del mobile
- Under-top installation, no cabinet sides needed to install the product
- Fixation sous comptoir, pas de nécessité d'installation sur les côtés du meuble

- Telaio in metallo verniciato
- Painted metal frame
- Cadre en métal peint

- Guide estrazione totale
- Full extension slides
- Glissières à sortie totale



Colori / Colours / Couleurs
Bianco / White / Blanc

LAB1UPG



TOT 50 L



5 min



min. 500 mm

W. 448
D. 352
H. 529

NEW



LAB1UPP



TOT 40 L



5 min



min. 550 mm

W. 488
D. 307
H. 529

NEW



Linea 560 Laundry



- Compatibile con sponde da cassetto:
- Available for drawer slides:
- Disponibles pour côtés des tiroirs:



- Adatto a mobili con pareti laterali da 16 a 19mm di spessore
- Suitable for cabinets with sides thickness from 16 to 19mm
- Adapte pour meubles avec épaisseur laterale de 16 à 19mm

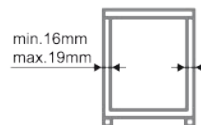

- Telaio in metallo con sponde in plastica
- Metal frame with plastic sides
- Cadre en métal avec bords en plastique

- Ceste dotate di maniglie laterali per facilitare la presa e incavi inferiori per agevolare lo svuotamento.
- Baskets equipped with side handles for a better grip and lower hollows to facilitate emptying.
- Paniers équipés de poignées latérales pour faciliter la prise et évidements inférieurs pour faciliter les vidanges.

Linea 560 Laundry



Colori / Colours / Couleurs
Bianco / White / Blanc

LAB1560B60



TOT 80 L



10 min



600 mm

D. 473
H. 506

LAB1560B50



TOT 50 L



10 min



500 mm

D. 473
H. 506

(Disponibile anche per cassetti profondità 450mm
Also available for 450mm drawer depth
Aussi disponible pour tiroirs profondeur 450mm

D. 423
H. 506

LAB1560B45



TOT 50 L



10 min



450 mm

D. 473
H. 506

(Disponibile anche per cassetti profondità 450mm
Also available for 450mm drawer depth
Aussi disponible pour tiroirs profondeur 450mm

D. 423
H. 506

LAB1560B40



TOT 40 L



10 min



400 mm

D. 473
H. 506

* Optional:
guide e sponde da cassetto
drawer slides and drawer sides
glissières et côtés pour tiroir

Linea 560 Laundry



- Telaio in metallo
- Metal frame
- Cadre en métal

- Guide estrazione totale
- Full extension slides
- Glissières à sortie totale

- Chiusura assistita e ammortizzata
- Assisted and damped closing
- Fermeture assistée et amortie

- Ceste dotate di maniglie laterali per facilitare la presa e incavi inferiori per agevolare lo svuotamento.
- Baskets equipped with side handles for a better grip and lower hollows to facilitate emptying.
- Paniers équipés de poignées latérales pour faciliter la prise et évidements inférieurs pour faciliter les vidanges.



Linea 580 Laundry

Colori / Colours / Couleurs
Bianco / White / Blanc



LAB1580

D. 500
H. 504



10 min



600 mm

SOFT
■■■■→

In dotazione 2 vaschette multiuso
Equipped with 2 multi-use removable trays
En dotation 2 bacs amovible tous usages



50
LITRI

D. 500
H. 504



TOT 50 L



10 min



450 mm

SOFT
■■■■→

In dotazione 1 vaschetta multiuso
Equipped with 1 multi-use removable tray
En dotation 1 bac amovible tous usages

Linea BH Laundry

Soluzioni per mobili con anta a ribalta
Solutions for bottom hinged cabinet
Solutions pour meubles avec porte à abattant



- Dotato di meccanismo di snodo per anta a ribalta frenato in apertura.
- Equipped with tilt out brake in opening mechanism for bottom hinged door.
- Équipé avec mécanisme ouverture compas pour porte à abattant avec frein en ouverture.

- Ceste dotate di maniglie laterali per facilitare la presa e incavi inferiori per agevolare lo svuotamento.
- Baskets equipped with side handles for a better grip and lower hollows to facilitate emptying.
- Paniers équipés de poignées latérales pour faciliter la prise et évidements inférieurs pour faciliter les vidanges.



Colori / Colours / Couleurs
Bianco / White / Blanc

LAB1BH1G



TOT **50 L**



5 min



min. **450 mm**

W. 400
D. **307**
H. 504

In dotazione:

- supporti in metallo verniciato
- cesta estraibile
- meccanismo di snodo

Equipment:

- painted metal supports
- removable basket
- tilt out mechanism

Dotation:

- supports en métal peint
- panier amovible
- mécanisme ouverture compas



LAB1BH1P



TOT **40 L**



5 min



min. **500 mm**

W. 438
D. **222**
H. 504

In dotazione:

- supporti in metallo verniciato
- cesta estraibile
- meccanismo di snodo

Equipment:

- painted metal supports
- removable basket
- tilt out mechanism

Dotation:

- supports en métal peint
- panier amovible
- mécanisme ouverture compas





Sous-Chef

Sous-Chef è un'innovativa soluzione per la cucina studiata per rispondere in maniera intelligente all'esigenza di organizzare al meglio anche gli spazi ridotti.

Dotata di vaschette removibili e posizionabili sul top della cucina, la colonna Sous-Chef permette di avere a portata di mano gli ingredienti e gli accessori di uso quotidiano. Le vaschette, infine, sono facilmente riposizionabili nel mobile agganciandole alla struttura centrale.

Sous-Chef is an innovative solution for the kitchen designed to organize even the smallest spaces at its best. Equipped with removable trays which can be freely placed on the top of the kitchen, the Sous-Chef kitchen column allows you to have the ingredients and accessories of everyday use at your fingertips. Finally, the trays are easily repositionable by hooking them to the central frame.

Sous-Chef est une solution innovante pour la cuisine conçue pour répondre de façon intelligente à la nécessité d'organiser même les plus petits espaces.

Équipé de vasques amovibles qui peuvent être placés sur le comptoir de la cuisine, le panier Sous-Chef vous permet d'avoir les ingrédients et les accessoires d'usage quotidien à portée de main. Enfin, les vasques sont facilement repositionnables en les accrochant à la structure centrale.

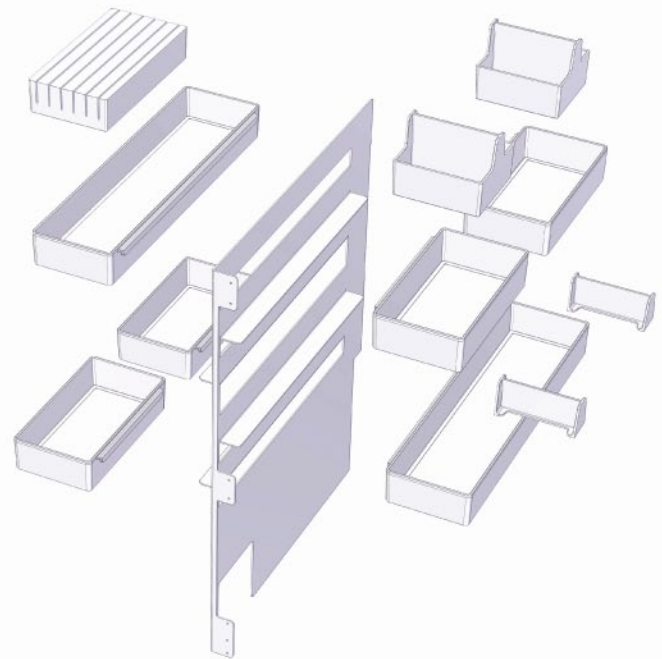
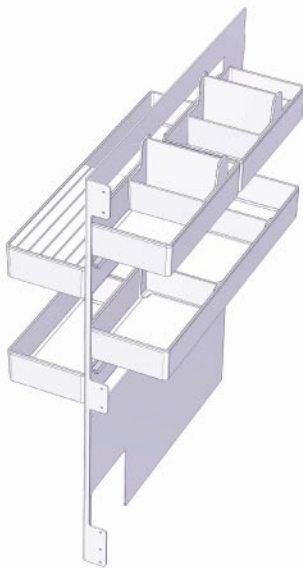



large capacity waste bins

Concept 560

new colour : Orion grey



Colore/Colour/Couleur:
Grigio orione/Orion grey/Gris orion

- Disponibile per base 300, 400, 450, 500, 600, 800, 900 mm e per profondità 500 e 450 mm
- Available for bases 300, 400, 450, 500, 600, 800, 900 mm and for 500 and 450 mm depth
- Disponibles pour bases 300, 400, 450, 500, 600, 800, 900 mm et pour profondeur 500 et 450 mm

- Capacità totale fino a 80 L
- Total capacity up to 80 L
- Capacité totale jusqu'à 80 L

- Secchi dotati di coperchio
- Bins equipped with lids
- Bacs munis de couvercle

- Due altezze disponibili: H463 e H298mm
- Two heights available: H463 and H298mm
- Deux hauteurs disponibles: H463 et H298mm

- Adatto a mobili con pareti laterali da 16 a 19mm di spessore
- Suitable for cabinets with sides thickness from 16 to 19mm
- Adapte pour meubles avec épaisseur laterale de 16 à 19mm

- Telaio in metallo con sponde in plastica. Supporti centrali in metallo
- Metal frame with plastic sides. Metal middle brackets
- Cadre en métal avec bords en plastique. Support central en métal

large capacity waste bins

Concept 560
new colour : Orion grey



- Compatibile con sponde da cassetto:
- Available for drawer slides:
- Disponibles pour côtés des tiroirs:



Optional / En option:

MYZYME™ ATOMIZING SYSTEM

- Coperchio brevettato per la diffusione del liquido enzimatico MYZYME™. Disponibile per secchi da 17 e da 29 L.
- Patented lid with incorporated atomizing system for enzymatic liquid MYZYME™. Available for 17 and 29 L bin.
- Couvercle breveté avec système intégré de nébulisation pour liquide enzymatique MYZYME™. Disponibles pour bacs de 17 et 29 L.

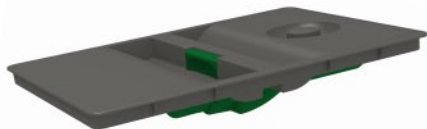

Optional / En option:

- coperchio ad incasso, in plastica o in metallo
- built-in plastic or metal lid
- couvercle encastrable, en plastique ou en métal

coperchio in metallo
metal lid
couvercle en métal

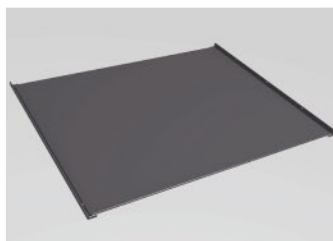

coperchio in plastica
plastic lid
couvercle en plastique

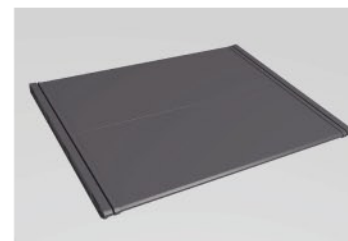



Gollinucci s.r.l. a Socio Unico
Via Dino Rondani, 250
47522 Cesena (FC) Italia
Tel +39 0547 318 234
Fax +39 0547 318 489
C.F. & P.I 02439640406
info@gollinucci.com

www.gollinucci.com