



FLOOR SPRINGS

CISA SERIES

Hardwares & Accessories

- Floor Springs
 - F5003/4 Series
 - F5500 Series
 - F8500 Series

- Accessories
 - Double Action Door - Adjustable Top Center and Door Strap
 - Single Action Door - Offset Accessories
 - Floor Pivot Bearing
 - TP24SS Series Top Pivot
 - PL10, PF 10, PF20, PF30 and PF40 Series Glass Door Patch Fitting/Patch Lock

Warranties	
Mechanical	2 years
Electronic	2 years

Mechanical	2 years
Electronic	2 years



F5003/4 Series

FLOOR SPRINGS



CISA F5003/4 floor springs are suitable for a wide range of applications, including shop fronts, malls, internal doors, and office buildings. These floor springs undergo a rigorous testing process of up to 500,000 cycles, ensuring their reliability and durability for any application.

Features

- **Exceptional quality** - Made of high-grade cast-iron body
- Fixed closing force of 3 or 4, depending on model
- **Durable** - Robust design handles up to 150 kg doors
- Adjustable closing and latching speed
- **Wide door opening angle** - Up to 180° (single action accessories)
- **Optional hold** - Open at 90°
- **High efficiency mechanism** - Offers maximum user convenience
- **Wide selection of interchangeable spindles** - Fits any floor covering or threshold application.
- Complies to EN1154:1996
- Tested to 500,000 cycles

Warranties

Mechanical	International Warranty*
Electronic	International Warranty*

*Please refer to the International Warranty agreement.

Dimensions

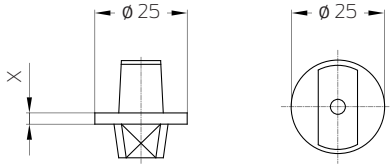
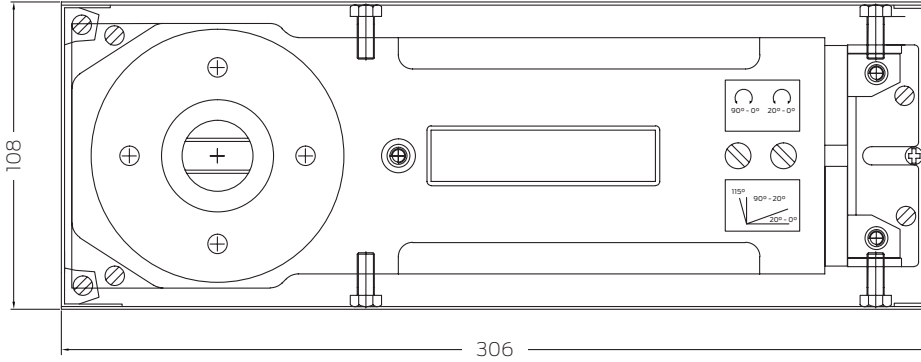
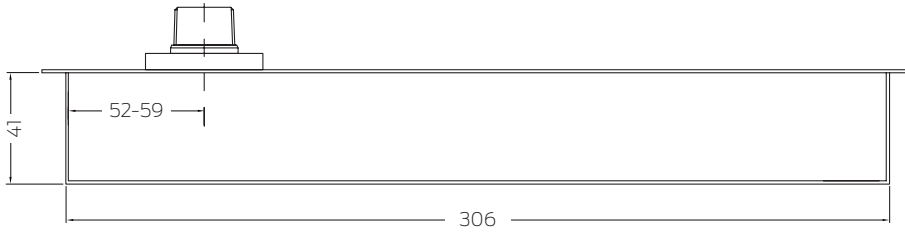

Expandable Spindle

X	3	5	10	15	20	25	30	35	40	45	50

All measurements are in mm.

Technical specifications

Model	F5003 EN3	F5004 EN4
Closing Force acc to EN1154	EN 3	EN 4
Adjustable Closing Force	No	No
Max Door Width (mm)	950	1100
Max Door Weight (kg)	150	150
Adjustable Closing Speed	90° - 15°	90° - 15°
Adjustable Latching Speed	15° - 0°	15° - 0°
Hold Open	Optional 90°	Optional 90°
Max Opening Angle (Hinge Side)	180°	180°
Back Check	-	-
Delay Action	-	-
Handling	Non-Handed	Non-Handed
Dimension (mm)	306 (L) / 108 (W) / 41 (H)	306 (L) / 108 (W) / 41 (H)
Extended Spindle (mm)	3 / 5 / 10 / 15 / 20 / 25 / 30 / 35 / 40 / 45 / 50	3 / 5 / 10 / 15 / 20 / 25 / 30 / 35 / 40 / 45 / 50
Compliance	EN1154:1996	EN1154:1996



F5500 Series

FLOOR SPRINGS

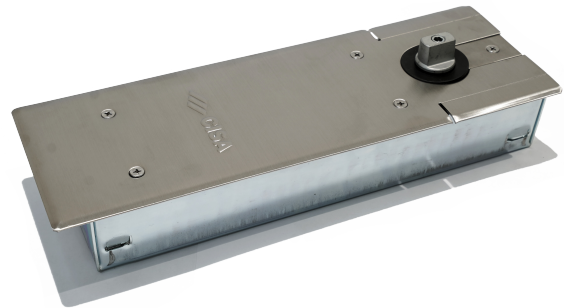

The CISA F5500 floor springs are specifically engineered for high-traffic locations that have either single or double action doors. Their power-adjustable size range from EN 1 - 4 makes them an ideal choice for a variety of applications such as timber, metal, and tempered glass doors.

Features

- **Exceptional quality** - Made of high-grade cast-iron body
- **Adjustable power size EN1-4** - Provides flexibility for installations requiring both barrier-free and non-barrier-free openings.
- **Durable** - Robust design handles up to 150 kg doors
- Adjustable closing and latching speed
- **Wide door opening angle** - Up to 180°
- **Optional hold** - Open at 90°
- **High efficiency mechanism** - Offers maximum user convenience
- **Wide selection of interchangeable spindles** - Fits any floor covering or threshold application.
- Complies to EN1154:1996, SS332:2018
- Tested to 500,000 cycles

Warranties

Mechanical	International Warranty*
Electronic	International Warranty*

*Please refer to the International Warranty agreement.

Dimensions

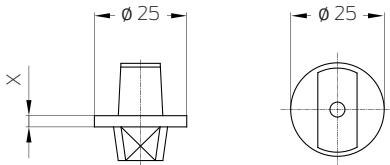
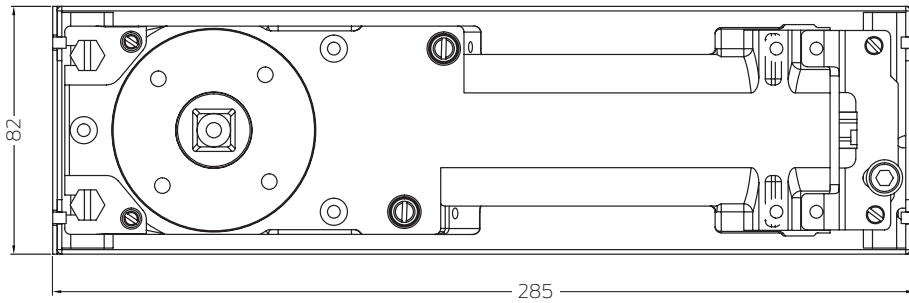
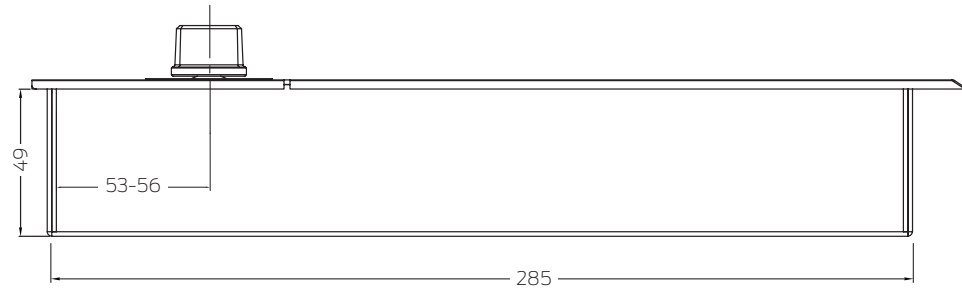

Expandable Spindle

X	3	5	10	15	20	25	30	35	40	45	50

All measurements are in mm.

Technical specifications

Model	F5500
Closing Force acc to EN1154	EN 1 - 4
Adjustable Closing Force	Yes
Max Door Width (mm)	1100
Max Door Weight (kg)	150
Adjustable Closing Speed	170° - 15°
Adjustable Latching Speed	15° - 0°
Hold Open	Optional 90°
Max Opening Angle (Hinge Side)	180°
Back Check	Yes
Delay Action	-
Handling	Non-Handed
Dimension (mm)	285 (L) / 82 (W) / 50 (H)
Extended Spindle (mm)	3 / 5 / 10 / 15 / 20 / 25 / 30 / 35 / 40 / 45 / 50
Compliance	EN1154:1996, SS332:2018



F8500 Series

FLOOR SPRINGS



The CISA F8500 floor springs are designed to handle different door types weighing up to 300kg, making them suitable for harsh weather conditions and high-traffic environments such as hospitals, shopping centers, and buildings with fire-resistant glass doors. These floor springs are constructed with robust materials and meet the ANSI Grade 1 standards, ensuring their strength and dependability.

Features

- **Exceptional quality** - Made of high-grade cast-iron body
- **Adjustable power size EN1-6** - Provides flexibility for installations requiring both barrier-free and non-barrier-free openings.
- **Durable** - Heavy duty design handles up to 300 kg doors
- **Wide selection of interchangeable spindles** - Fits any floor covering or threshold application.
- **Adjustable closing and latching speed**
- **Wide door opening angle** - Up to 180°
- **Optional hold** - Open at 90°
- **High efficiency mechanism** - Offers maximum user convenience
- **Highest safety standards** - Complies to ANSI A156.4 and EN1154:1996 (Pending)

Warranties

Mechanical	International Warranty*
Electronic	International Warranty*

*Please refer to the International Warranty agreement.

Dimensions

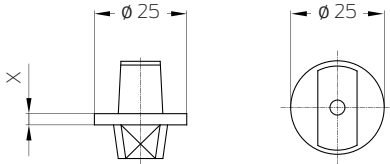
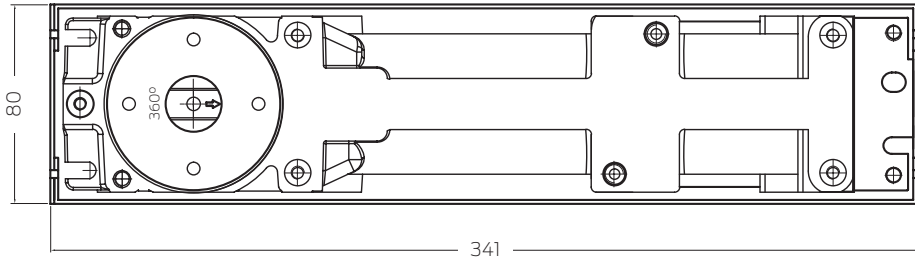
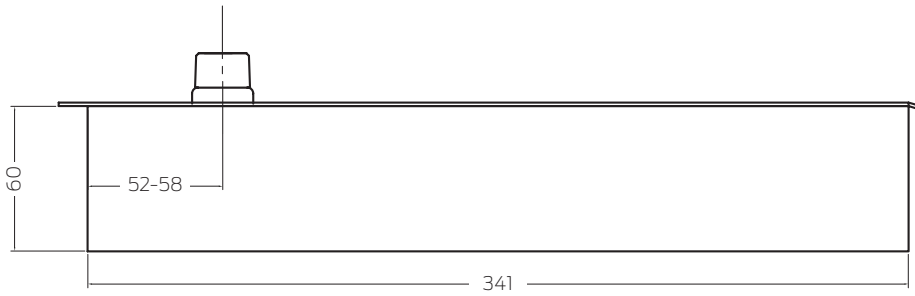

Expandable Spindle

X	3	5	10	15	20	25	30	35	40	45	50

All measurements are in mm.

Technical specifications

Model	F8500
Closing Force acc to EN1154	EN 1 - 6
Adjustable Closing Force	Yes
Max Door Width (mm)	1400
Max Door Weight (kg)	300
Adjustable Closing Speed	170° - 15°
Adjustable Latching Speed	15° - 0°
Hold Open	Optional 90°
Max Opening Angle (Hinge Side)	180°
Back Check	-
Delay Action	Option
Handling	Non-Handed
Dimension (mm)	341 (L) / 80 (W) / 60 (H)
Extended Spindle (mm)	3 / 5 / 10 / 15 / 20 / 25 / 30 / 35 / 40 / 45 / 50
Compliance	ANSI A156.4 and EN1154:1996 (Pending)



SAP-300

ACCESSORIES - SINGLE
ACTION PIVOT SET

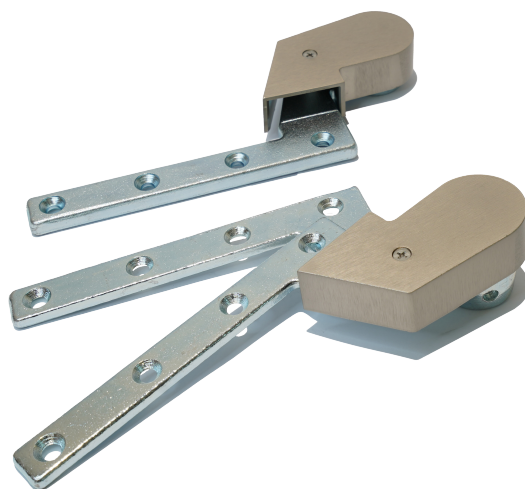

SAP-300 single action pivot set is designed for single-direction swing doors. It is specifically designed to work seamlessly with all CISA series floor springs and pivots, making installation easy and efficient for doors of any function or material.

The SAP-300 includes a reversible set of SAP-300TP Top Pivot and SAP-300BS Bottom Strap, capable of supporting doors weighing up to 250kg.

Warranties

Mechanical	International Warranty*
------------	-------------------------

*Please refer to the International Warranty agreement.

Dimensions

SAP-300TP Top Pivot

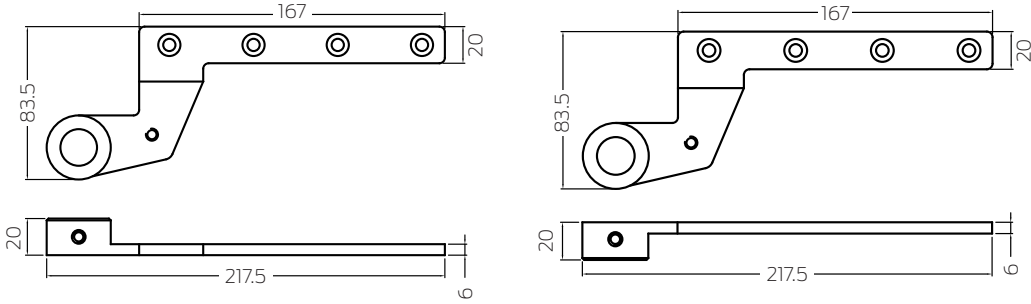

SAP-300BS Bottom Strap

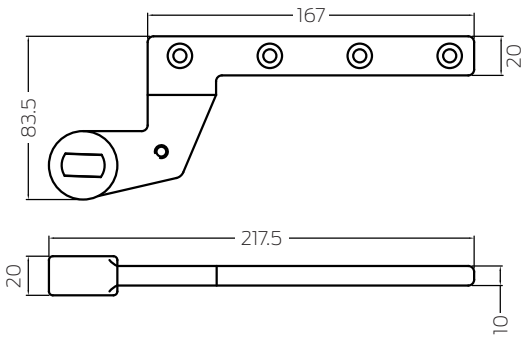

Cover Cap

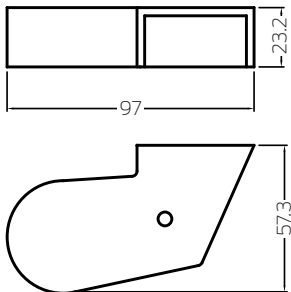

All measurements are in mm.



DAP-300 DAP-150

ACCESSORIES - DOUBLE ACTION PIVOT SET

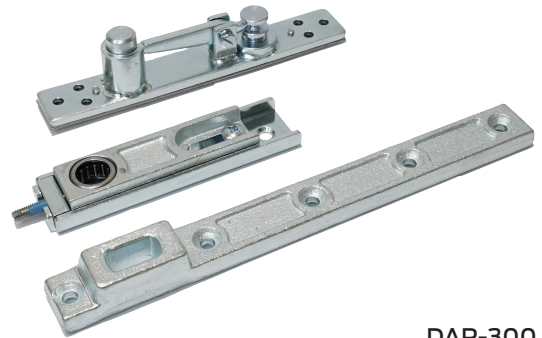

DAP-300

The DAP-300 and DAP-150 double action pivot set are designed to work seamlessly with all CISA series floor springs and pivots, making installation effortless and efficient for doors of any function or material. The top pivot comes with ball bearings for smooth and effective operation. Additionally, the top spindle can be adjusted with ease to achieve precise positioning during installation.

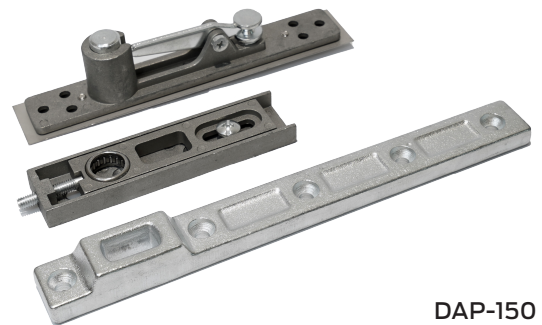

DAP-150

DAP-300 Double Action Pivot set consists of

- DAP-300TP Top Pivot
- DAP-300BS Bottom Strap

Maximum weight capacity - 300kg

DAP-150 Double Action Pivot set consists of

- DAP-150TP Top Pivot
- DAP-150BS Bottom Strap

Maximum weight capacity - 150kg

Warranties

Mechanical	International Warranty*
------------	-------------------------

*Please refer to the International Warranty agreement.

Dimensions

DAP-300TP Top Pivot

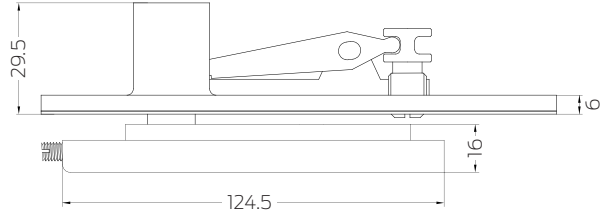
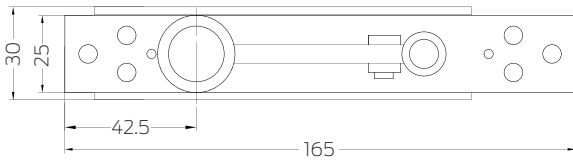

DAP-300BS Bottom Strap

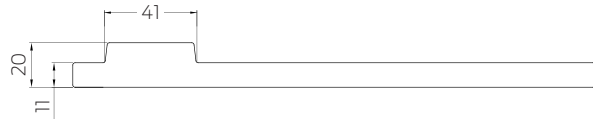
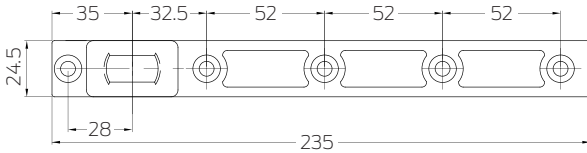

DAP-150TP Top Pivot

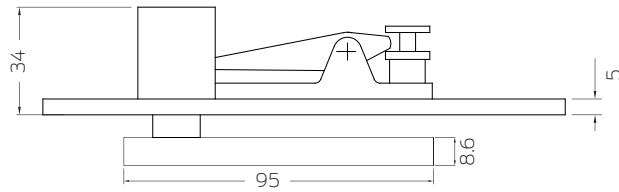
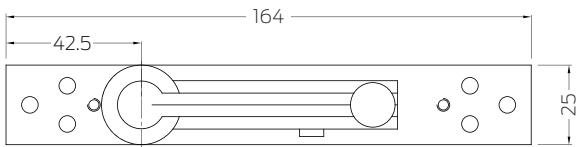

DAP-150BS Bottom Strap

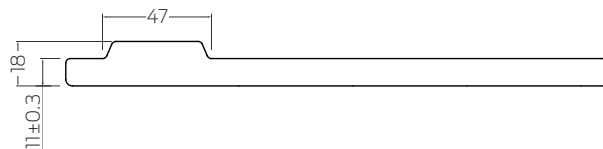
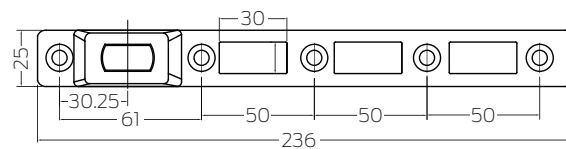

All measurements are in mm.



Patch Fitting

ACCESSORIES -
GLASS DOOR

To ensure that your glass door works seamlessly with our floor springs, CISA provides a variety of glass door accessories. Our range of accessories is designed to accommodate glass doors of various thicknesses, ranging from 10mm to 19mm.

Patch fitting selection



PF40



PF30

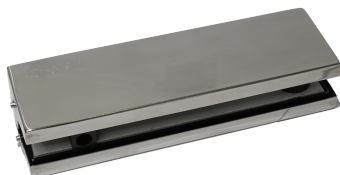

PF20



PF10



PL10



PT24

Model	Application	SSS	PSS	Max Door Thickness (mm)	Max Weight (kg)
PF10 - 12	Bottom Patch	Y	Y	12	150
PF20 - 12	Top Patch	Y	Y	12	150
PF30 - 12	Corner Patch	Y	Y	12	150
PF40 - 12	L-Shape Patch	Y	Y	12	150
PL10 - 12	Patch Lock	Y	Y	12	150
PF10 - 15	Bottom Patch	Y	Y	15	150
PF20 - 15	Top Patch	Y	Y	15	150
PF30 - 15	Corner Patch	Y	Y	15	150
PF40 - 15	L-Shape Patch	Y	Y	15	150
PL10 - 15	Patch Lock	Y	Y	15	150

We offer patch fittings that can be customized to fit door thicknesses that are not listed above. Simply make a request for the specific door thickness you need.

Include dimensions



FP-300 FP-150

ACCESSORIES - FLOOR PIVOT BEARING

The FP-300 and FP-150 floor pivot bearings, featuring angular contact roller bearings, are designed to work with all CISA patch fittings, single action pivots, and double action pivots. These floor pivot bearings, constructed with a stainless steel body, offer exceptional durability and can support maximum door weights of 300kg and 150kg respectively.



FP-300



FP-150

Warranties

Mechanical	International Warranty*
------------	-------------------------

*Please refer to the International Warranty agreement.

Dimensions

FP-300 Floor Pivot Bearing

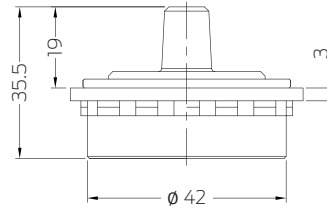
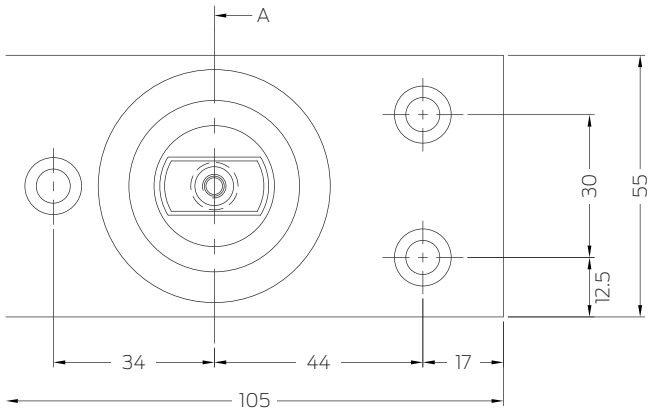

Cross-section 'A' view

FP-150 Floor Pivot Bearing

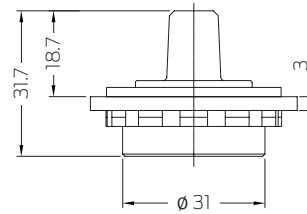
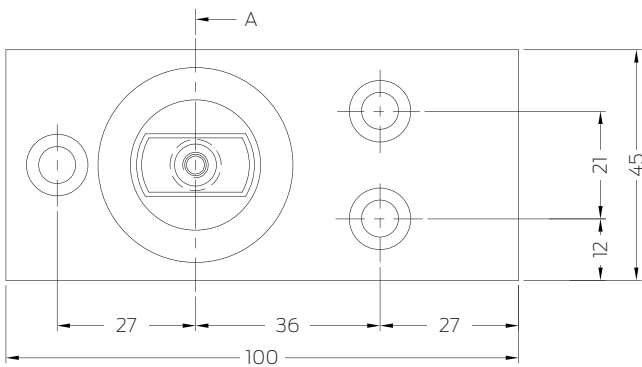

Cross-section 'A' view

All measurements are in mm.