

Pack Contents:

1. 2 x Hanger and Bolt
2. 2 x Mounting brackets
3. 8 x Fixing screws
4. 1 x Spanner

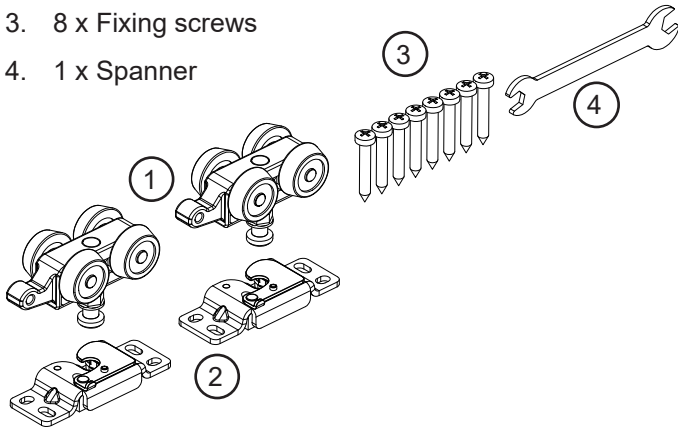

1. Panel Preparation

- (a) Use bracket as template to mark the hole position on panel.
Make sure the 2 brackets are in the same orientation.

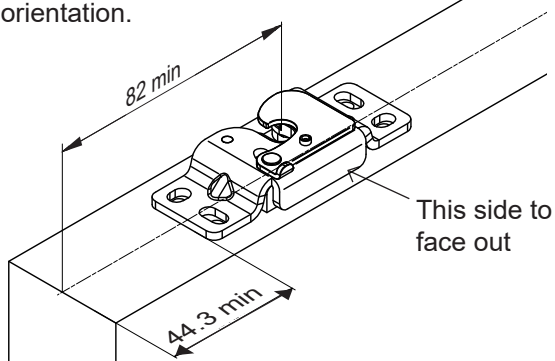

- (b) Pre-drill the pilot holes for 10G screws.

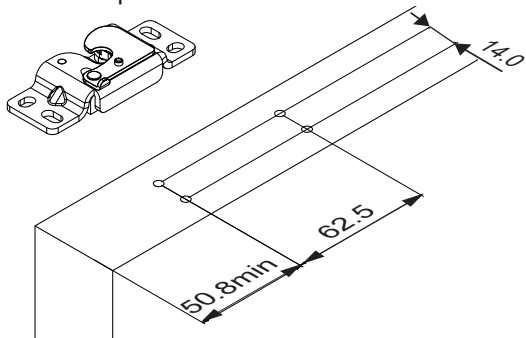

- (c) Fix bracket with mounting screws provided.

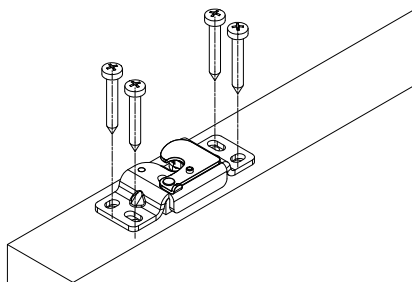

2. Hardware Installation

- (a) Insert hanger with bolt into the track.

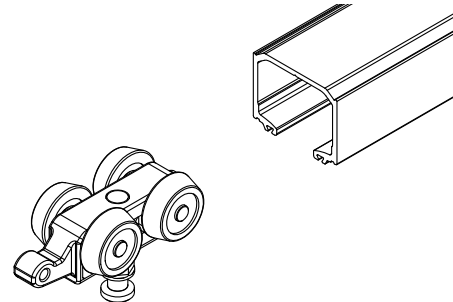

- (b) If using 120CS clip stops: please ensure correct orientation of hanger to engage the 120CS

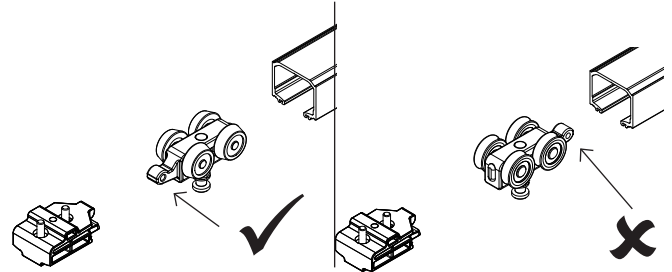

3. Attach Panel to Hanger

- (a) Carefully lift the door panel with brackets, lining up the opening of the bracket with the bolt on hangers.

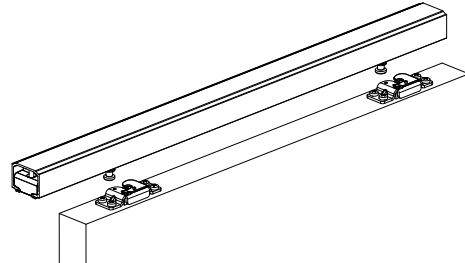

- (b) Locate the hanger bolt into the bracket opening until the locking lever clips into the locked position.

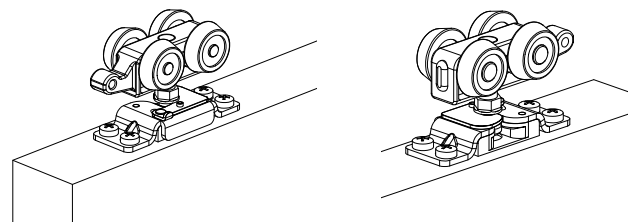

- (c) Adjust the height using the spanner provided. Clockwise will lower the panel, and anti-clockwise will raise the panel.

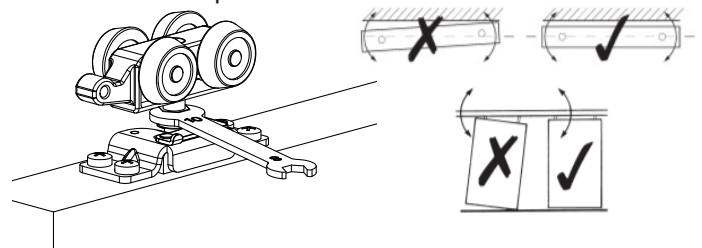

4. Releasing the Panel

- (a) To release the panel: push locking lever to open position; lift the panel and slide the bracket away from the bolt hanger.

Note that the locking lever will automatically return to the locked position.

Do not use the bracket if the locking lever fails to return to the locked position.

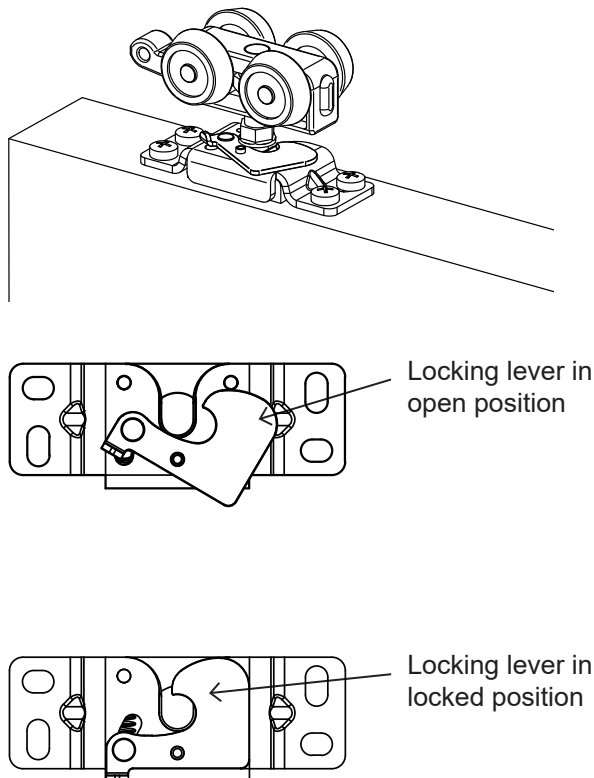

5. System Overview

End elevation of 120F track, 57JNP hanger, panel and 101N guide option.

Alternative track profiles and guide options available.

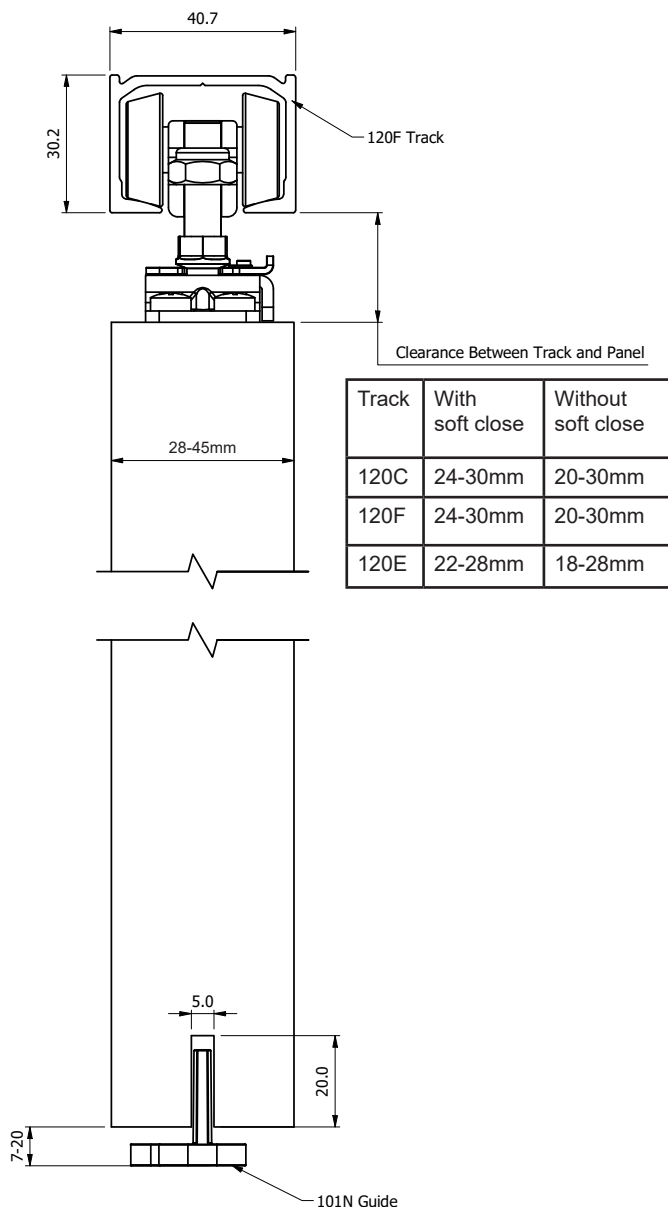

Care and Maintenance

General

Inspect all fixing bolts for tightness every six months, including those securing brackets. Tighten if necessary. Routinely check for wear and if excessively worn, the part should be replaced.

To help prevent surface corrosion, wash regularly with soap or mild detergent and warm water followed by rinsing with clean cold water and wipe dry.

Track

Keep track free from obstruction and excessive dirt or water. Visible surfaces should be cleaned using a damp cloth and mild detergent, then wiped dry.

Hangers

All hangers are fitted with lubricated ball-bearings, requiring no greasing. If doors 'settle' and door clearance is reduced causing friction, raise the door by the hanger adjustment nuts. Wash as per the above recommendation and apply a light application of corrosion preventative to all surfaces, using a dry cloth to remove excess.

Guides

Guide roller and guide channel must be kept clear and free of obstructions. Wash as per the above recommendation and apply a light application of corrosion preventative to all surfaces, using a dry cloth to remove excess.

Allegion (Australia) Pty Ltd
 Freephone: 1800 098 094
 Email: info.au@allegion.com
www.brio.com.au

Allegion (New Zealand) Limited
 Freephone: 0800 477 869
 Email: nzinfo@allegion.com
www.brionz.com

